



# CE EMC TEST REPORT

for

**Programmable Logic Controller**

**MODEL: A-6 Series**

Test Report Number:

T141013E02-E

Issued for

**Yottacontrol co.**

8F-1, No.286-3, Hsin-Ya Rd, Chien-Chen Zone(806), Kaohsiung, Taiwan

Issued By:

**Compliance Certification Services Inc.**

Wugu Laboratory

No.11, Wugong 6th Rd., Wugu Dist.,  
New Taipei City 24891, Taiwan. (R.O.C.)

TEL: 886-2-2299-9720

FAX: 886-2-2299-9721

**Issued Date: October 31, 2014**



Testing Laboratory  
1309



ACCREDITED  
TESTING CERT #0824.01

**Note:** This report shall not be reproduced except in full, without the written approval of Compliance Certification Services Inc. This document may be altered or revised by Compliance Certification Services Inc. personnel only, and shall be noted in the revision section of the document. The client should not use it to claim product endorsement by TAF, A2LA, NIST or any government agencies. The test results in the report only apply to the tested sample.



**Revision History**

Rev.	Issue Date	Revisions	Effect Page	Revised By
00	October 31, 2014	Initial Issue	ALL	Kelly Cheng



**TABLE OF CONTENTS**

**1 TEST CERTIFICATION..... 4**

**2 TEST RESULT SUMMARY..... 5**

**3 EUT DESCRIPTION..... 6**

**4 TEST METHODOLOGY..... 7**

4.1. DECISION OF FINAL TEST MODE ..... 7

4.2. EUT SYSTEM OPERATION..... 7

**5 SETUP OF EQUIPMENT UNDER TEST ..... 8**

5.1. DESCRIPTION OF SUPPORT UNITS ..... 8

5.2. CONFIGURATION OF SYSTEM UNDER TEST ..... 8

**6 FACILITIES AND ACCREDITATIONS ..... 9**

6.1. FACILITIES..... 9

6.2. ACCREDITATIONS ..... 9

6.3. MEASUREMENT UNCERTAINTY ..... 10

**7 EMISSION TEST..... 11**

7.1. CONDUCTED EMISSION MEASUREMENT .....11

7.2. CONDUCTED EMISSION MEASUREMENT AT TELECOMMUNICATION PORTS .... 14

7.3. RADIATED EMISSION MEASUREMENT ..... 17

7.4. HARMONICS CURRENT MEASUREMENT ..... 25

7.5. VOLTAGE FLUCTUATION AND FLICKS MEASUREMENT ..... 27

**8 IMMUNITY TEST..... 29**

8.1. GENERAL DESCRIPTION ..... 29

8.2. GENERAL PERFORMANCE CRITERIA DESCRIPTION ..... 30

8.3. ELECTROSTATIC DISCHARGE (ESD) ..... 31

8.4. RADIATED, RADIO-FREQUENCY, ELECTROMAGNETIC FIELD (RS) ..... 41

8.5. ELECTRICAL FAST TRANSIENT (EFT) ..... 46

8.6. SURGE IMMUNITY TEST ..... 49

8.7. CONDUCTED RADIO FREQUENCY DISTURBANCES (CS) ..... 52

8.8. POWER FREQUENCY MAGNETIC FIELD ..... 56

8.9. VOLTAGE DIP & VOLTAGE INTERRUPTIONS ..... 59

**9 PHOTOGRAPHS OF THE TEST CONFIGURATION..... 61**

**APPENDIX 1 - PHOTOGRAPHS OF EUT**



# 1 TEST CERTIFICATION

<b>Product:</b>	Programmable Logic Controller	
<b>Model:</b>	A-6 Series	
<b>Brand:</b>	Yottacontrol	
<b>Applicant:</b>	<b>Yottacontrol co.</b> 8F-1, No.286-3, Hsin-Ya Rd, Chien-Chen Zone(806), Kaohsiung, Taiwan	
<b>Manufacturer:</b>	<b>Yottacontrol co.</b> 8F-1, No.286-3, Hsin-Ya Rd, Chien-Chen Zone(806), Kaohsiung, Taiwan	
<b>Tested:</b>	October 28, 2014	
<b>Applicable Standards:</b>	<b>EN 55022: 2010/AC: 2011</b> EN 61000-3-2:2006+A1:2009+A2:2009 EN 61000-3-3:2013	<b>EN 55024:2010</b> IEC 61000-4-2:2008 IEC 61000-4-3:2006+A1:2007+A2:2010 IEC 61000-4-4:2012 IEC 61000-4-5:2005 IEC 61000-4-6:2008 IEC 61000-4-8:2009 IEC 61000-4-11:2004

Deviation from Applicable Standard
None

The above equipment has been tested by Compliance Certification Services Inc., and found compliance with the requirements set forth in the technical standards mentioned above. The results of testing in this report apply only to the product/system, which was tested. Other similar equipment will not necessarily produce the same results due to production tolerance and measurement uncertainties.

**Approved by:**

**Reviewed by:**

---

Gary Wu  
Section Manager

---

Angel Cheng  
Section Manager



## 2 TEST RESULT SUMMARY

EMISSION			
Standard	Item	Result	Remarks
EN 55022: 2010/AC: 2011	Conducted (Power Port)	N/A	Not applicable, because EUT not connect to AC Main Source direct.
	Conducted (Telecom port)	N/A	Not applicable, the EUT doesn't have LAN Port or Modem port.
	Radiated	PASS	Meet Class B limit
EN 61000-3-2:2006+A1:2009+A2:2009	Harmonic current emissions	N/A	Not applicable, because EUT not connect to AC Main Source direct.
EN 61000-3-3:2013	Voltage fluctuations & flicker	N/A	Not applicable, because EUT not connect to AC Main Source direct.

IMMUNITY [ EN 55024 (2010) ]			
Standard	Item	Result	Remarks
IEC 61000-4-2:2008	ESD	PASS	Meets the requirements of Performance Criterion B
IEC 61000-4-3:2006+A1:2007+A2:2010	RS	PASS	Meets the requirements of Performance Criterion A
IEC 61000-4-4:2012	EFT	PASS	Meets the requirements of Performance Criterion B
IEC 61000-4-5:2005	Surge	PASS	Meets the requirements of Performance Criterion B
IEC 61000-4-6:2008	CS	PASS	Meets the requirements of Performance Criterion A
IEC 61000-4-8:2009	PFMF	PASS	Meets the requirements of Performance Criterion A
IEC 61000-4-11:2004	Voltage dips & voltage variations	N/A	Not applicable, because EUT not connect to AC Main Source direct.

**Note:**

1. The statements of test result on the above are decided by the request of test standard only; the measurement uncertainties are not factored into this compliance determination.
2. The information of measurement uncertainty is available upon the customer's request.



### 3 EUT DESCRIPTION

<b>Product</b>	Programmable Logic Controller
<b>Brand Name</b>	Yottacontrol
<b>Model</b>	A-6 Series
<b>Applicant</b>	Yottacontrol co.
<b>Housing material</b>	Plastic
<b>Identify Number</b>	T141013E02
<b>Received Date</b>	October 13, 2014
<b>EUT Power Rating</b>	Powered from Battery : DC 24V
<b>AC Power Cord Type</b>	N/A
<b>DC Power Cord Type</b>	N/A

*Remark: 1. Client consigns two samples to test (model number: A-6188-D, A-6189D-D). Therefore, the testing Lab. just guarantees the unit, which has been tested.*

#### I/O Port

I/O PORT TYPES	Q'TY	TESTED WITH
1). DC Port	2	2
2). Signal Port	20	20



## 4 TEST METHODOLOGY

### 4.1. DECISION OF FINAL TEST MODE

The EUT was tested together with the above additional components, and a configuration, which produced the worst emission levels, was selected and recorded in this report.

The test configuration / modes are as the following:

1. The following test mode was scanned during the preliminary test:

Pre-Test Mode
<b>Mode 1: Normal Operation</b>

2. After the preliminary scan, the following test mode was found to produce the highest emission level.

Final Test Mode		
Emission	Conducted Emission	N/A
	Radiated Emission	<b>Mode 1</b>
	PH & PF	N/A
Immunity (ESD, RS, EFT, Surge, CS, PM)		<b>Mode 1</b>
Immunity (DIPS)		N/A

Then, the above highest emission mode of the configuration of the EUT and cable was chosen for all final test items.

### 4.2. EUT SYSTEM OPERATION

1	Setup the EUT and simulators as shown on 5.2.
2	Turn on the power of all equipment.
3	Start test.

**Note:** Test program is self-repeating throughout the test.



## 5 SETUP OF EQUIPMENT UNDER TEST

### 5.1. DESCRIPTION OF SUPPORT UNITS

The EUT has been tested as an independent unit together with other necessary accessories or support units. The following support units or accessories were used to form a representative test configuration during the tests.

#### Peripherals Devices:

No.	Equipment	Trade Name	Model No.	Serial No.	FCC ID / BSMI ID	Power Cord
	N/A					

No.	Cable Name	Unit	Shielded	Length	With Core
(A)	Signal Cable	20	<input type="checkbox"/> Shielded, <input checked="" type="checkbox"/> Non	0.3 m	<input type="checkbox"/> With Core, <input checked="" type="checkbox"/> Non

#### Note:

- 1) All the equipment/cables were placed in the worst-case configuration to maximize the emission during the test.
- 2) Grounding was established in accordance with the manufacturer's requirements and conditions for the intended use.

### 5.2. CONFIGURATION OF SYSTEM UNDER TEST

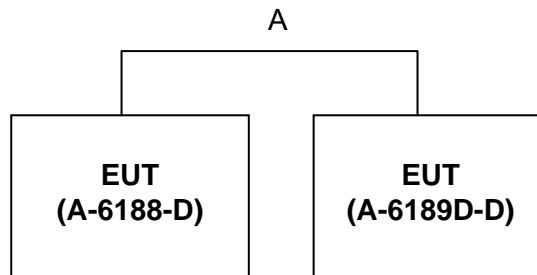





## 6 FACILITIES AND ACCREDITATIONS

### 6.1. FACILITIES

All measurement facilities used to collect the measurement data are located at:

- No.11, Wugong 6th Rd., Wugu Dist., New Taipei City 24891, Taiwan. (R.O.C.)
- No.139, Wugong Rd., Wugu Dist., New Taipei City 24891, Taiwan (R.O.C.)
- No.81-1, Lane 210, Bade 2nd Rd., Lujhu Township, Taoyuan County 33841, TAIWAN, R.O.C.
- No.163-1, Jhongsheng Rd. Sindian City, Taipei County 23151, Taiwan.

The sites are constructed in conformance with the requirements of ANSI C63.4 and CISPR Publication 22. All receiving equipment conforms to CISPR 16-1-1, CISPR 16-1-2, CISPR 16-1-3, CISPR 16-1-4 and CISPR 16-1-5.

### 6.2. ACCREDITATIONS

Our laboratories are accredited and approved by the following accreditation body according to ISO/IEC 17025.

<b>Taiwan</b>	TAF (TAF 1309)
<b>USA</b>	A2LA (0824.01)

The measuring facility of laboratories has been authorized or registered by the following approval agencies.

<b>Canada</b>	Industry Canada (3M Semi Anechoic Chamber: IC 2324G-1 / IC 2324G-2 / 2324J-1 / 2324J-2 to perform)
<b>Norway</b>	Nemko VCCI 966 Chamber C:
<b>Japan</b>	Radiated emissions: 30 MHz -1000 MHz: R-3282 / Above 1GHz: G-146 10M Chamber: Radiated emissions: 30 MHz -1000 MHz: R-3283 / Above 1GHz: G-147 Conducted Emission B: C-3700 / T-1839
<b>USA</b>	FCC (3M Semi Anechoic Chamber (FCC MRA: TW1039) to perform FCC Part 15 measurements)

Copies of granted accreditation certificates are available for downloading from our web site, <http://www.ccsrf.com>



### 6.3. MEASUREMENT UNCERTAINTY

Where relevant, the following measurement uncertainty levels have been estimated for tests performed on the EUT as specified in CISPR 16-4-2:

Measurement	Frequency	Uncertainty
Conducted emissions	0.15MHz ~ 30MHz	N/A
Radiated emissions	30MHz ~ 200MHz	±3.9163 dB
	200MHz ~1000MHz	±3.9030 dB
	Above 1GHz	N/A

This uncertainty represents an expanded uncertainty expressed at approximately the 95% confidence level using a coverage factor of k=2.

Consistent with industry standard (e.g. CISPR 22:2008, clause 11, Measurement Uncertainty) determining compliance with the limits shall be base on the results of the compliance measurement. Consequently the measure emissions being less than the maximum allowed emission result in this be a compliant test or passing test.

The acceptable measurement uncertainty value without requiring revision of the compliance statement is base on conducted and radiated emissions being less than UCISPR which is 3.6dB and 5.2dB respectively. CCS values (called ULab in CISPR 16-4-2) is less than UCISPR as shown in the table above. Therefore, MU need not be considered for compliance.



## 7 EMISSION TEST

### 7.1. CONDUCTED EMISSION MEASUREMENT

#### 7.1.1. LIMITS

FREQUENCY (MHz)	Class A (dBuV)		Class B (dBuV)	
	Quasi-peak	Average	Quasi-peak	Average
0.15 - 0.5	79	66	66 - 56	56 - 46
0.50 - 5.0	73	60	56	46
5.0 - 30.0	73	60	60	50

**Note:**

1. The lower limit shall apply at the transition frequencies.
2. The limit decreases in line with the logarithm of the frequency in the range of 0.15 to 0.50 MHz.
3. All emanations from a class A/B digital device or system, including any network of conductors and apparatus connected thereto, shall not exceed the level of field strengths specified above.

#### 7.1.2. TEST INSTRUMENTS

Conducted Emission Room				
Name of Equipment	Manufacturer	Model	Serial Number	Calibration Due
N/A				



**7.1.3. TEST PROCEDURES** (please refer to measurement standard or CCS SOP PA-031)

**Procedure of Preliminary Test**

- The EUT and Support equipment, if needed, was set up as per the test configuration to simulate typical usage per the user's manual. When the EUT is a tabletop system, a wooden table with a height of 0.8 meters is used and is placed on the ground plane as per EN 55022 (see Test Facility for the dimensions of the ground plane used). When the EUT is a floor standing equipment, it is placed on the ground plane, which has a 15 cm non-conductive covering to insulate the EUT from the ground plane.
- All I/O cables were positioned to simulate typical actual usage as per EN 55022.
- The test equipment EUT installed received AC main power, through a Line Impedance Stabilization Network (LISN), which supplied power source and was grounded to the ground plane.
- All support equipment power received from a second LISN.
- The EUT test program was started. Emissions were measured on each current carrying line of the EUT using an EMI Test Receiver connected to the LISN powering the EUT.
- The Receiver scanned from 150kHz to 30MHz for emissions in each of the test modes.
- During the above scans, the emissions were maximized by cable manipulation.
- The test mode(s) described in Item 4.1 were scanned during the preliminary test.
- After the preliminary scan, we found the test mode described in Item 4.1 producing the highest emission level.
- The EUT configuration and cable configuration of the above highest emission levels were recorded for reference of the final test.

**Procedure of Final Test**

- EUT and support equipment were set up on the test bench as per the configuration with highest emission level in the preliminary test.
- A scan was taken on both power lines, Line 1 and Line 2, recording at least the six highest emissions. Emission frequency and amplitude were recorded into a computer in which correction factors were used to calculate the emission level and compare reading to the applicable limit.
- The test data of the worst-case condition(s) was recorded.

**7.1.4. TEST SETUP**

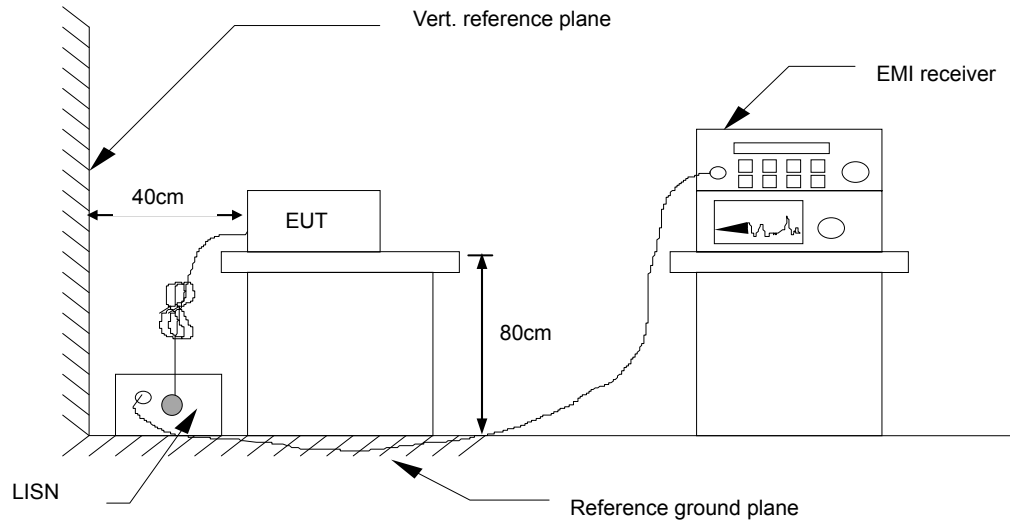

- For the actual test configuration, please refer to the related item – Photographs of the Test Configuration.

**7.1.5. DATA SAMPLE**

Frequency (MHz)	QuasiPeak reading (dBuV)	Average reading (dBuV)	Correctrion factor (dB)	QuasiPeak result (dBuV)	Average result (dBuV)	QuasiPeak. limit (dBuV)	Average limit (dBuV)	QuasiPeak margin (dB)	Average margin (dB)	Remark
x.xx	43.95	33.00	10.00	53.95	43.00	56.00	46.00	-2.05	-3.00	Pass

Frequency (MHz) = Emission frequency in MHz  
 Reading (dBuV) = Uncorrected Analyzer/Receiver reading + Insertion loss of LISN, if it > 0.5 dB  
 Correction Factor (dB) = LISN Factor + Cable loss  
 Result (dBuV) = Raw reading converted to dBuV and CF added  
 Limit (dBuV) = Limit stated in standard  
 Margin (dB) = Result (dBuV) – Limit (dBuV)

**7.1.6. TEST RESULTS**

***Not applicable, because EUT not connect to AC Main Source direct.***



## 7.2. CONDUCTED EMISSION MEASUREMENT AT TELECOMMUNICATION PORTS

### 7.2.1. LIMITS

For Class A Equipment

FREQUENCY (MHz)	Voltage Limit (dBuV)		Current Limit (dBuA)	
	Quasi-peak	Average	Quasi-peak	Average
0.15 ~ 0.5	97 ~ 87	84 ~ 74	53 ~ 43	40 ~ 30
0.5 ~ 30.0	87	74	43	30

**Note:** The limits decrease linearly with the logarithm of the frequency in the range 0.15 MHz to 0.5 MHz.

For Class B Equipment

FREQUENCY (MHz)	Voltage Limit (dBuV)		Current Limit (dBuA)	
	Quasi-peak	Average	Quasi-peak	Average
0.15 - 0.5	84 ~ 74	74 ~ 64	40 ~ 30	30 ~ 20
0.5 - 30.0	74	64	30	20

**Note:** The limits decrease linearly with the logarithm of the frequency in the range 0.15 MHz to 0.5 MHz.

### 7.2.2. TEST INSTRUMENTS

Conducted Emission Room				
Name of Equipment	Manufacturer	Model	Serial Number	Calibration Due
N/A				



**7.2.3. TEST PROCEDURE** (please refer to measurement standard or CCS SOP PA-031)

- Selecting ISN for unscreened cable or a current probe for screened cable to take measurement.
- The port of the EUT was connected to the remote side support equipment through the ISN/Current Probe and communication in normal condition.
- Making a overall range scan by using the test receiver controlled by controller and record at least six highest emissions for showing in the test report.
- Emission frequency and amplitude were recorded into a computer in which correction factors were used to calculate the emission level and compare reading to the applicable limit.
- In case of measuring on the screened cable, the current limit shall be applied; otherwise the voltage limit should be applied.

***Not applicable, the EUT doesn't have LAN Port or Modem port.***

**7.2.4. TEST SETUP**

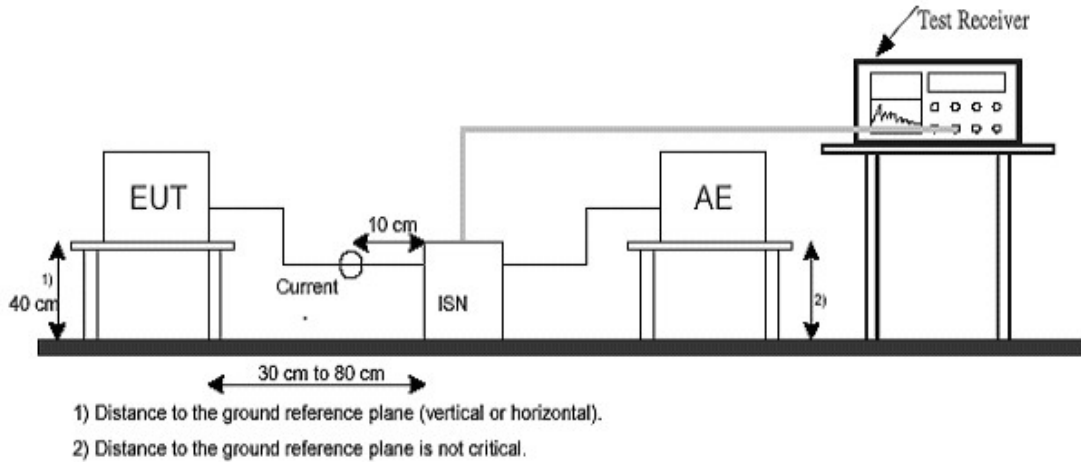

- For the actual test configuration, please refer to the related item – Photographs of the Test Configuration.

**7.2.5. DATA SAMPLE**

Frequency (MHz)	QuasiPeak reading (dBuV)	Average reading (dBuV)	Correction factor (dB)	QuasiPeak result (dBuV)	Average result (dBuV)	QuasiPeak limit (dBuV)	Average limit (dBuV)	QuasiPeak margin (dB)	Average margin (dB)	Remark
x.xx	43.95	33.00	10.00	53.95	43.00	74.00	64.00	-20.05	-21.00	Pass

Frequency (MHz) = Emission frequency in MHz  
 Reading (dBuV) = Uncorrected Analyzer/Receiver reading + Insertion loss of LISN, if it > 0.5 dB  
 Correction Factor (dB) = ISN Factor + Cable loss  
 Result (dBuV) = Raw reading converted to dBuV and CF added  
 Limit (dBuV) = Limit stated in standard  
 Margin (dB) = Result (dBuV) – Limit (dBuV)

**7.2.6. TEST RESULTS**

**Not applicable, the EUT doesn't have LAN Port or Modem port.**





### 7.3. RADIATED EMISSION MEASUREMENT

#### 7.3.1. LIMITS

##### Below 1GHz

FREQUENCY (MHz)	dBuV/m (At 10m)	
	Class A	Class B
30 ~ 230	40	30
230 ~ 1000	47	37

*Note: The lower limit shall apply at the transition frequencies.*

##### Above 1GHz

FREQUENCY (MHz)	Class A (dBuV/m) (At 3m)		Class B (dBuV/m) (At 3m)	
	Average	Peak	Average	Peak
1000 ~ 3000	56	76	50	70
3000 ~ 6000	60	80	54	74

*Note: The lower limit shall apply at the transition frequencies.*

According to EN 55022:2010 clause 6.2, the measurement frequency range shown in the following table:

Highest frequency generated or used within the EUT or on which the EUT operates or tunes (MHz)	Upper frequency of measurement range (MHz)
Less than 108	1000
108-500	2000
500-1000	5000
Above 1000	5 times of the highest frequency or 6GHz, whichever is less



**7.3.2. TEST INSTRUMENTS**

<b>Wugu 10M Chamber</b>				
<b>Name of Equipment</b>	<b>Manufacturer</b>	<b>Model</b>	<b>Serial Number</b>	<b>Calibration Due</b>
Spectrum Analyzer	Agilent	E4446A	MY48250297	10/01/2015
EMI Test Receiver	R&S	ESCI	100961	09/03/2015
EMI Test Receiver	R&S	ESCI	100962	09/03/2015
Pre-Amplifier	HP	8447D	2944A07754	05/05/2015
Pre-Amplifier	HP	8447D	2944A08150	05/05/2015
Pre-Amplifier	EMC	EMC012645	980056	05/05/2015
Pre-Amplifier	MITEQ	AMF-6F-260400-40-8P	985646	08/07/2015
Bilog Antenna	TESEQ	CBL 6112D	31674	09/08/2015
Bilog Antenna	TESEQ	CBL6112D	31675	09/08/2015
Horn Antenna	EMCO	3117	55167	01/20/2015
Horn Antenna	EMCO	3116	26370	12/29/2014
Coaxial Cable	Huber+Suhner	104PEA	33948/4PEA	05/05/2015
Coaxial Cable	Huber+Suhner	104PEA	33949/4PEA	05/05/2015
Coaxial Cable	Huber+Suhner	104	330026/4	05/05/2015
Coaxial Cable	Huber+Suhner	104	330029/4	05/05/2015
Coaxial Cable	Huber+Suhner	104	329382/4	05/05/2015
Coaxial Cable	Huber+Suhner	104	330028/4	05/05/2015
Turn Table	CCS	CC-T-1F	N/A	N.C.R
Antenna Tower	CCS	CC-A-1F	N/A	N.C.R
Controller	CCS	CC-C-1F	N/A	N.C.R
Antenna Tower	Sunol Sciences	TLT2	031010-5	N.C.R.
Controller	Sunol Sciences	SC104V	031010-1	N.C.R.
Site NSA	CCS	N/A	N/A	11/22/2014
Site VSWR	CCS	N/A	N/A	11/28/2014
Test S/W	EZ-EMC (CCS-3A1RE)			

**NOTE:** 1. The calibration interval of the above test instruments is 12 months and the calibrations are traceable to NML/ROC and NIST/USA.  
 2. N.C.R = No Calibration Request.



**7.3.3. TEST PROCEDURE** (please refer to measurement standard or CCS SOP PA-031)

**Frequency range 30MHz ~ 1GHz**

1. The EUT was placed on the top of a rotating table 0.8 meters above the ground at a 10 meter semi-anechoic chamber room. The table was rotated 360 degrees to determine the position.
2. The EUT was set 10 meters away from the interference-receiving antenna, which was mounted on the top of a variable-height antenna tower.
3. The height of antenna is varied from one meter to four meter above the ground to determine the maximum value of the field strength. Both horizontal and vertical polarizations of the antenna are set to make the measurement.
4. For each suspected emission, the EUT was arranged to its worst case and then the antenna was turned to heights for 1 meter to 4 meters and the turn table was turned from 0 degrees to 360 degrees to find the maximum reading.
5. The test-receiver system was set to quasi-peak detect function and specified bandwidth with maximum hold mode when the test frequency is below 1GHz.

NOTE: The resolution bandwidth of test receiver/spectrum analyzer is 120kHz for Quasi-peak detection (QP) at frequency below 1GHz.

**Frequency range above 1GHz**

1. The EUT was placed on the top of a rotating table 0.8 meters above the ground at a 3 meter semi-anechoic chamber room. The table was rotated 360 degrees to determine the position.
2. The EUT was set 3 meters away from the directional antenna, which was pointed towards the source of the emission within the EUT. This could be done by either pointing the antenna at an angle towards the source of the emission, or by rotating the EUT, in both height and polarization, to maximize the measured emission.
3. The height of antenna can be varied from one meter to four meters, the height of adjustment depends on the EUT height and the antenna 3 dB beamwidth both, to detect the maximum value of the field strength. Both horizontal and vertical polarizations of the antenna are set to make the measurement.
4. For each suspected emission, the EUT was arranged to its worst case and then the antenna was turned to heights and the rotatable table was turned from 0 degrees to 360 degrees to find the maximum reading.
5. The test-receiver system was set to peak and average detect function and specified bandwidth with maximum hold mode when the test frequency is above 1GHz.

NOTE:

1. The resolution bandwidth is 1MHz and video bandwidth of test spectrum analyzer is 1 MHz for peak detection at above 1GHz. The resolution bandwidth is 1MHz and video bandwidth of test spectrum analyzer is 100Hz for average detection at frequency above 1 GHz.
2. For measurement of frequency above 1GHz, the EUT was set 3 meters away from the directional antenna.

7.3.4. TEST SETUP

Below 1GHz

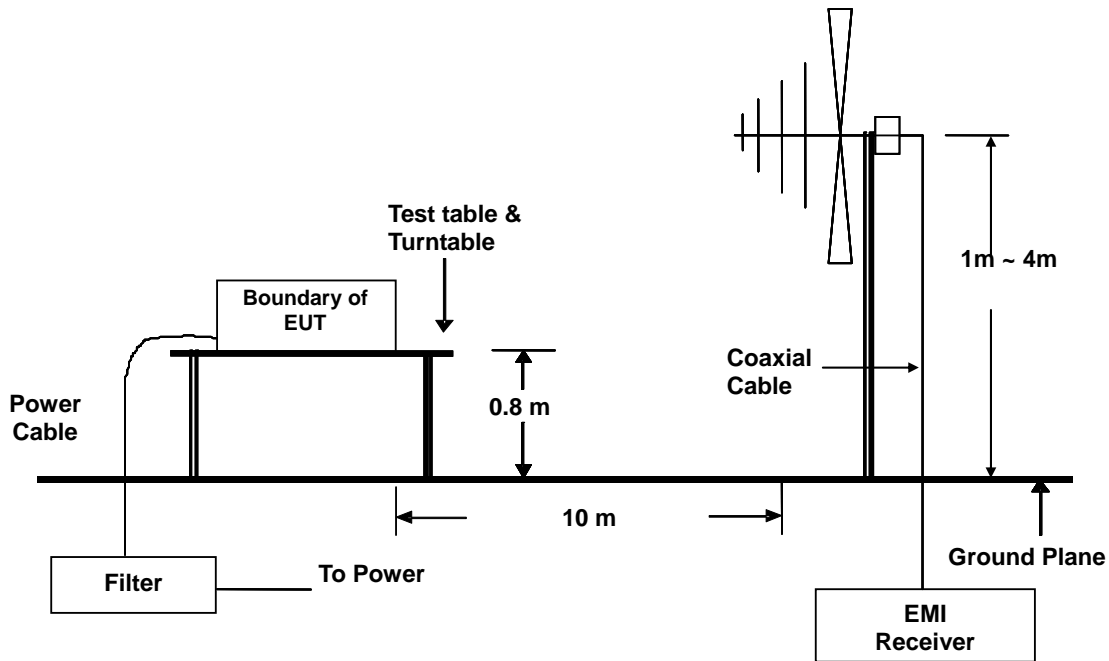

Above 1GHz

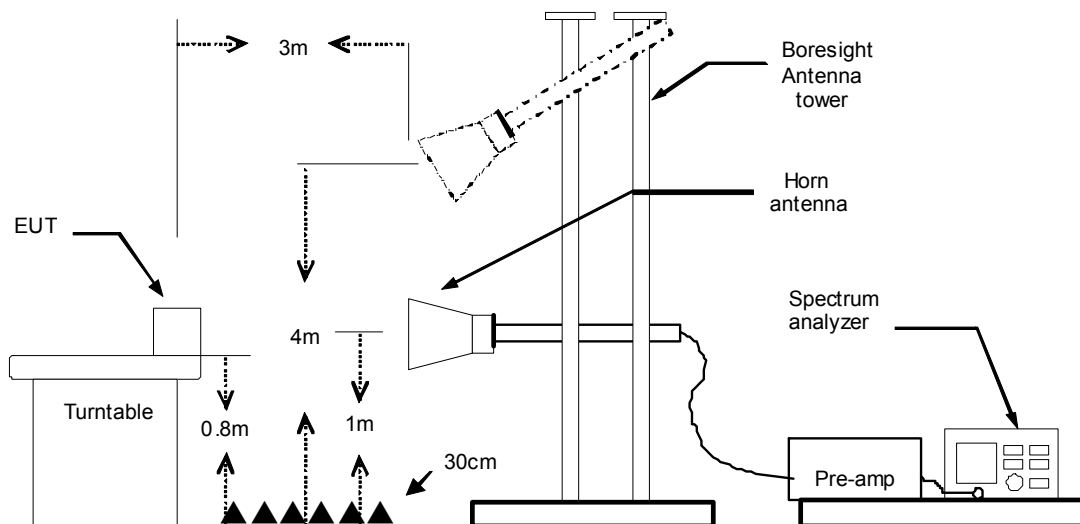

- For the actual test configuration, please refer to the related item – Photographs of the Test Configuration.



**7.3.5. DATA SAMPLE**

**Below 1GHz**

Frequency (MHz)	Reading (dBuV)	Correction Factor (dB/m)	Result (dBuV/m)	Limit (dBuV/m)	Margin (dB)	Height (cm)	Degree (°)	Remark
xx.xx	16.49	9.86	26.35	30.00	-3.65	116.00	101.00	QP

**Above 1GHz**

Frequency (MHz)	Reading (dBuV)	Correction Factor (dB/m)	Result (dBuV/m)	Limit (dBuV/m)	Margin (dB)	Height (cm)	Degree (°)	Remark
xx.xx	66.04	-20.61	45.43	70.00	-24.57	400	158	Peak
xx.xx	56.89	-14.91	41.98	50.00	-8.02	400	351	AVG

- Frequency (MHz) = Emission frequency in MHz
- Reading (dBuV) = Uncorrected Analyzer / Receiver reading
- Correction Factor (dB/m) = Antenna factor + Cable loss – Amplifier gain
- Result (dBuV/m) = Reading (dBuV) + Corr. Factor (dB/m)
- Limit (dBuV/m) = Limit stated in standard
- Margin (dB) = Result (dBuV/m) – Limit (dBuV/m)
- Q.P. = Quasi-Peak



7.3.6. TEST RESULTS

Below 1GHz

<b>Model No.</b>	A-6188-D	<b>Test Mode</b>	Mode 1
<b>Environmental Conditions</b>	26°C, 60% RH	<b>Test Date</b>	2014/10/28
<b>Antenna Pole</b>	Vertical	<b>Antenna Distance</b>	10m
<b>Detector Function</b>	Quasi-peak	<b>Tested by</b>	Moore Cheng

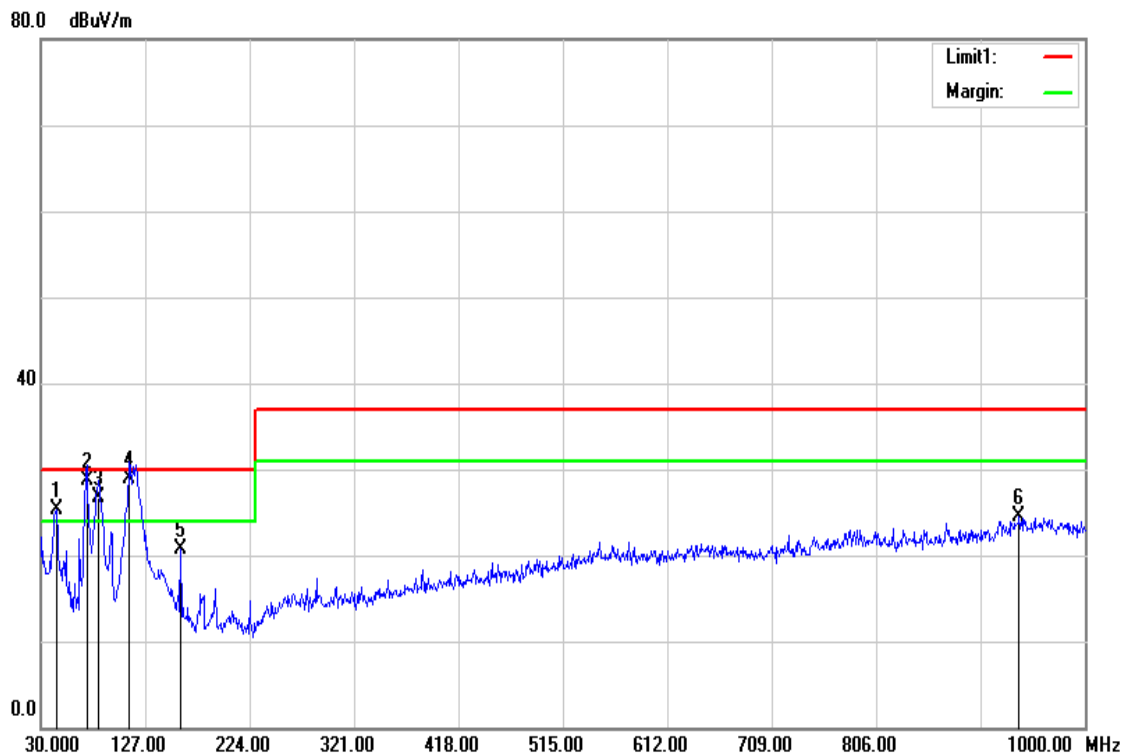

No.	Frequency (MHz)	Reading (dBuV)	Correction Factor (dB/m)	Result (dBuV/m)	Limit (dBuV/m)	Margin (dB)	Height (cm)	Degree (°)	Remark
1	44.5500	39.31	-14.02	25.29	30.00	-4.71	100	269	QP
2	72.6800	45.98	-17.32	28.66	30.00	-1.34	124	360	QP
3	83.3500	42.57	-15.90	26.67	30.00	-3.33	200	209	QP
4	112.4500	40.75	-11.91	28.84	30.00	-1.16	100	83	QP
5	159.9800	33.81	-13.07	20.74	30.00	-9.26	281	0	QP
6	938.8900	23.19	1.27	24.46	37.00	-12.54	200	360	QP

**Note:**

1. PK= Peak Reading; QP= Quasi-peak Reading.
2. The other emission levels were very low against the limit.



<b>Model No.</b>	A-6188-D	<b>Test Mode</b>	Mode 1
<b>Environmental Conditions</b>	26°C, 60% RH	<b>Test Date</b>	2014/10/28
<b>Antenna Pole</b>	Horizontal	<b>Antenna Distance</b>	10m
<b>Detector Function</b>	Quasi-peak.	<b>Tested by</b>	Moore Cheng

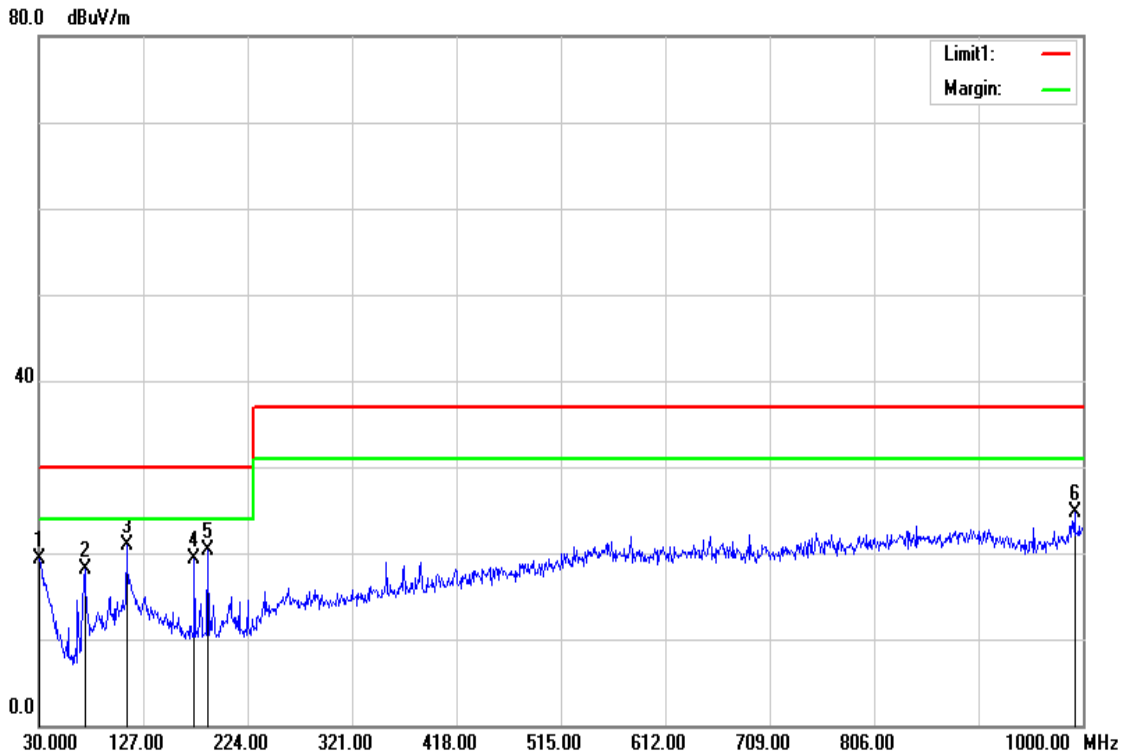

No.	Frequency (MHz)	Reading (dBuV)	Correction Factor (dB/m)	Result (dBuV/m)	Limit (dBuV/m)	Margin (dB)	Height (cm)	Degree (°)	Remark
1	30.0000	26.40	-7.00	19.40	30.00	-10.60	385	360	QP
2	72.6800	36.14	-17.99	18.15	30.00	-11.85	199	360	QP
3	111.4800	33.47	-12.59	20.88	30.00	-9.12	399	360	QP
4	174.5300	33.60	-14.23	19.37	30.00	-10.63	277	0	QP
5	187.1400	34.49	-14.24	20.25	30.00	-9.75	249	0	QP
6	992.2400	24.70	-0.08	24.62	37.00	-12.38	202	0	QP

**Note:**

1. PK= Peak Reading; QP= Quasi-peak Reading.
2. The other emission levels were very low against the limit.



**Above 1GHz**

<b>Model No.</b>	A-6188-D	<b>Test Mode</b>	N/A
<b>Environmental Conditions</b>	N/A	<b>Test Date</b>	N/A
<b>Antenna Pole</b>	N/A	<b>Antenna Distance</b>	N/A
<b>Highest frequency generated or used</b>	8MHz	<b>Upper frequency</b>	1000MHz
<b>Detector Function</b>	N/A	<b>Tested by</b>	N/A

**Note:** No applicable, when the highest frequency of the internal sources of the EUT is less than 108MHz, the measurement shall only be made up to 1GHz.





## 7.4. HARMONICS CURRENT MEASUREMENT

### 7.4.1. LIMITS OF HARMONICS CURRENT MEASUREMENT

Limits for Class A equipment		Limits for Class D equipment		
Harmonics Order n	Max. permissible harmonics current A	Harmonics Order n	Max. permissible harmonics current per watt mA/W	Max. permissible harmonics current A
Odd harmonics		Odd Harmonics only		
3	2.30	3	3.4	2.30
5	1.14	5	1.9	1.14
7	0.77	7	1.0	0.77
9	0.40	9	0.5	0.40
11	0.33	11	0.35	0.33
13	0.21	13	0.30	0.21
15<=n<=39	0.15x15/n	15<=n<=39	3.85/n	0.15x15/n
Even harmonics				
2	1.08			
4	0.43			
6	0.30			
8<=n<=40	0.23x8/n			

**Note:**

1. Class A and Class D are classified according to item 7.4.3.
2. According to section 7 of EN 61000-3-2, the above limits for all equipment except for lighting equipment having an active input power > 75 W and no limits apply for equipment with an active input power up to and including 75 W.

### 7.4.2. TEST INSTRUMENTS

Name of Equipment	Manufacturer	Model	Serial Number	Calibration Due
N/A				



**7.4.3. TEST PROCEDURE** (please refer to measurement standard or CCS SOP PA-029)

- The EUT was placed on the top of a wooden table 0.8 meters above the ground and operated to produce the maximum harmonic components under normal operating conditions for each successive harmonic component in turn.
- The classification of EUT is according to section 5 of EN 61000-3-2.
- The EUT is classified as follows:  
Class A: Balanced three-phase equipment, Household appliances excluding equipment as Class D, Tools excluding portable tools, Dimmers for incandescent lamps, audio equipment, equipment not specified in one of the three other classes.  
Class B: Portable tools; Arc welding equipment which is not professional equipment.  
Class C: Lighting equipment.  
Class D: Equipment having a specified power less than or equal to 600 W of the following types: Personal computers and personal computer monitors and television receivers.
- The correspondent test program of test instrument to measure the current harmonics emanated from EUT is chosen. The measure time shall be not less than the time necessary for the EUT to be exercised.

**7.4.4. TEST SETUP**

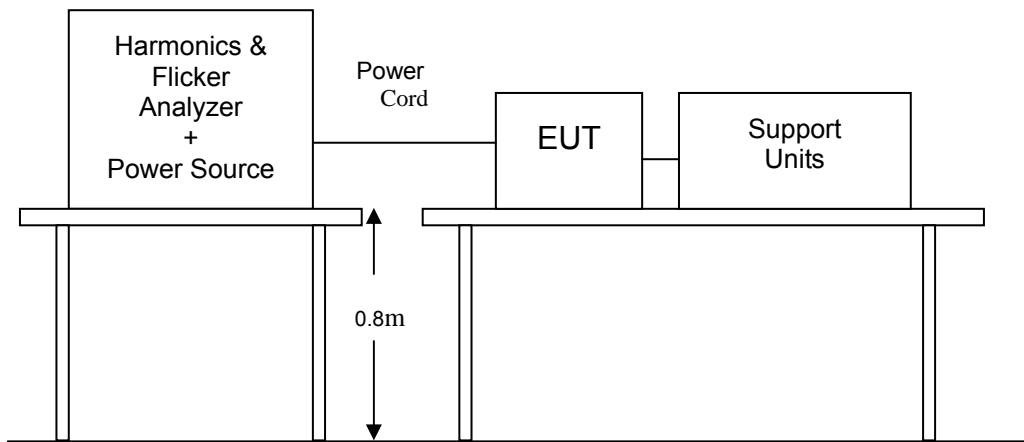

- For the actual test configuration, please refer to the related item – Photographs of the Test Configuration.

**7.4.5. TEST RESULTS**

***Not applicable, because EUT not connect to AC Main Source direct.***



## 7.5. VOLTAGE FLUCTUATION AND FLICKS MEASUREMENT

### 7.5.1. LIMITS OF VOLTAGE FLUCTUATION AND FLICKS MEASUREMENT

TEST ITEM	LIMIT	REMARK
P <sub>st</sub>	1.0	P <sub>st</sub> means short-term flicker indicator.
P <sub>lt</sub>	0.65	P <sub>lt</sub> means long-term flicker indicator.
T <sub>dt</sub> (ms)	500	T <sub>dt</sub> means maximum time that dt exceeds 3 %.
d <sub>max</sub> (%)	4%	d <sub>max</sub> means maximum relative voltage change.
dc (%)	3.3%	dc means relative steady-state voltage change

### 7.5.2. TEST INSTRUMENTS

Name of Equipment	Manufacturer	Model	Serial Number	Calibration Due
N/A				

### 7.5.3. TEST PROCEDURE (please refer to measurement standard or CCS SOP PA-030)

- The EUT was placed on the top of a wooden table 0.8 meters above the ground and operated to produce the most unfavorable sequence of voltage changes under normal operating conditions.
- During the flick measurement, the measure time shall include that part of whole operation cycle in which the EUT produce the most unfavorable sequence of voltage changes. The observation period for short-term flicker indicator is 10 minutes and the observation period for long-term flicker indicator is 2 hours.



#### 7.5.4. TEST SETUP

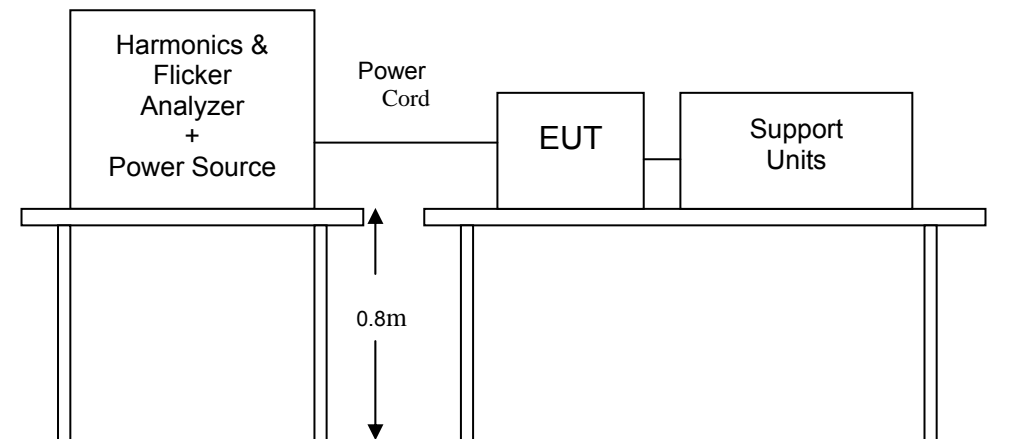

- For the actual test configuration, please refer to the related item – Photographs of the Test Configuration.

#### 7.5.5. TEST RESULTS

***Not applicable, because EUT not connect to AC Main Source direct.***



## 8 IMMUNITY TEST

### 8.1. GENERAL DESCRIPTION

Product Standard	EN 55024:2010	
	Test Type	Minimum Requirement
Basic Standard, Specification, and Performance Criterion required	IEC 61000-4-2	Electrostatic Discharge – ESD: 8KV air discharge, 4kV Contact discharge, Performance Criterion B
	IEC 61000-4-3	Radio-Frequency Electromagnetic Field Susceptibility Test – RS: 80 ~1000 MHz, 3V/m, 80% AM(1kHz), Performance Criterion A
	IEC 61000-4-4	Electrical Fast Transient/Burst - EFT, AC Power Port: 1kV DC Power Port: 0.5kV Signal Ports and Telecommunication Ports: 0.5kV Performance Criterion B
	IEC 61000-4-5	Combination Wave for power port 1.2/50µs Open Circuit Voltage 8/20µs Short Circuit Current
		Combination Wave for Signal and Telecommunication port 10/700µs Open Circuit Voltage 5/320µs Short Circuit Current  AC Power Port ~ line to line: 1kV, line to earth (ground): 2kV DC Power Port ~ line to earth: 0.5kV Performance Criterion B Signal and Telecommunication Ports ~ line to ground: 1kV Performance Criterion C
	IEC 61000-4-6	Conducted Radio Frequency Disturbances Test –CS: 0.15 ~ 80 MHz, 3Vrms, 80% AM, 1kHz, Performance Criterion A
	IEC 61000-4-8	Power frequency magnetic field immunity test 50 Hz, 1A/m Performance Criterion A
	IEC 61000-4-11	Voltage Dips: i) >95% reduction for 0.5 periods, Performance Criterion B ii) 30% reduction for 25 periods, Performance Criterion C Voltage Interruptions: >95% reduction for 250 periods Performance Criterion C



## 8.2. GENERAL PERFORMANCE CRITERIA DESCRIPTION

<b>Criteria A:</b>	The apparatus shall continue to operate as intended without operator intervention. No degradation of performance or loss of function is allowed below a performance level specified by the manufacturer, when the apparatus is used as intended. The performance level may be replaced by a permissible loss of performance. If the manufacturer does not specify the minimum performance level or the permissible performance loss, then either of these may be derived from the product description and documentation, and by what the user may reasonably expect from the equipment if used as intended.
<b>Criteria B:</b>	After test, the apparatus shall continue to operate as intended without operator intervention. No degradation of performance or loss of function is allowed, after the application of the phenomenon below a performance level specified by the manufacturer, when the apparatus is used as intended. The performance level may be replaced by a permissible loss of performance.  During the test, degradation of performance is however allowed. However, no change of operating state if stored data is allowed to persist after the test. If the manufacturer does not specify the minimum performance level or the permissible performance loss, then either of these may be derived from the product description and documentation, and by what the user may reasonably expect from the equipment if used as intended.
<b>Criteria C:</b>	Temporary loss of function is allowed, provided the functions is self-recoverable or can be restored by the operation of controls by the user in accordance with the manufacturer instructions.  Functions, and/or information stored in non-volatile memory, or protected by a battery backup, shall not be lost.



### 8.3. ELECTROSTATIC DISCHARGE (ESD)

#### 8.3.1. TEST SPECIFICATION

<b>Basic Standard:</b>	IEC 61000-4-2
<b>Discharge Impedance:</b>	330 ohm / 150 pF
<b>Discharge Voltage:</b>	Air Discharge: 2 ; 4 ; 8 kV (Direct) Contact Discharge: 2 ; 4 kV (Direct/Indirect)
<b>Polarity:</b>	Positive & Negative
<b>Number of Discharge:</b>	Air Discharge: min. 10 times at each test point for each polarity Contact Discharge: min. 200 times in total
<b>Discharge Mode:</b>	Single Discharge 1 second minimum

#### 8.3.2. TEST INSTRUMENT

IMMUNITY SHIELDED ROOM				
Name of Equipment	Manufacturer	Model	Serial Number	Calibration Due
ESD Simulator	SCHAFFNER	NSG 438	170	01/27/2015

**Note:** The calibration interval of the above test instruments is 12 months and the calibrations are traceable to NML/ROC and NIST/USA.



**8.3.3. TEST PROCEDURE** (please refer to measurement standard or CCS SOP PA-022)

The discharges shall be applied in two ways:

- a) Contact discharges to the conductive surfaces and coupling planes:  
The EUT shall be exposed to at least 200 discharges, 100 each at negative and positive polarity, at a minimum of four test points. One of the test points shall be subjected to at least 50 indirect discharges to the center of the front edge of the **Horizontal Coupling Plane (HCP)**. The remaining three test points shall each receive at least 50 direct contact discharges. If no direct contact test points are available, then at least 200 indirect discharges shall be applied in the indirect mode. Test shall be performed at a maximum repetition rate of one discharge per second.
- b) Air discharges at slots and apertures and insulating surfaces:  
On those parts of the EUT where it is not possible to perform contact discharge testing, the equipment should be investigated to identify user accessible points where breakdown may occur. Such points are tested using the air discharge method. This investigation should be restricted to those area normally handled by the user. A minimum of 10 single air discharges shall be applied to the selected test point for each such area.

The basic test procedure was in accordance with IEC 61000-4-2:

- a) The EUT was located 0.1 m minimum from all side of the **HCP** (dimensions 1.6m x 0.8m).
- b) The support units were located another table 30 cm away from the EUT, but direct support unit was/were located at same location as EUT on the HCP and keep at a distance of 10 cm with EUT.
- c) The time interval between two successive single discharges was at least 1 second.
- d) Contact discharges were applied to the non-insulating coating, with the pointed tip of the generator penetrating the coating and contacting the conducting substrate.
- e) Air discharges were applied with the round discharge tip of the discharge electrode approaching the EUT as fast as possible (without causing mechanical damage) to touch the EUT. After each discharge, the ESD generator was removed from the EUT and re-triggered for a new single discharge. The test was repeated until all discharges were complete.
- f) At least ten single discharges (in the most sensitive polarity) were applied at the front edge of each **HCP** opposite the center point of each unit of the EUT and 0.1 meters from the front of the EUT. The long axis of the discharge electrode was in the plane of the **HCP** and perpendicular to its front edge during the discharge.
- g) At least ten single discharges (in the most sensitive polarity) were applied to the center of one vertical edge of the **Vertical Coupling Plane (VCP)** in sufficiently different positions that the four faces of the EUT were completely illuminated. The **VCP** (dimensions 0.5m x 0.5m) was placed vertically to and 0.1 meters from the EUT.



### 8.3.4. TEST SETUP

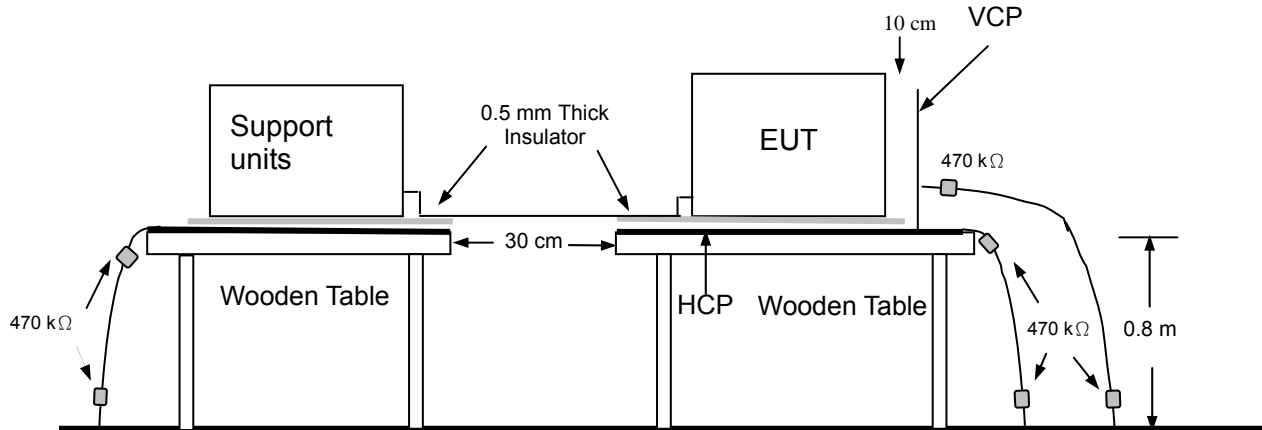

#### Ground Reference Plane

- For the actual test configuration, please refer to the related item – Photographs of the Test Configuration.

#### Note:

##### TABLETOP EQUIPMENT

The configuration consisted of a wooden table 0.8 meters high standing on the **Ground Reference Plane**. The **GRP** consisted of a sheet of aluminum at least 0.25mm thick, and 2.5 meters square connected to the protective grounding system. A **Horizontal Coupling Plane** (1.6m x 0.8m) was placed on the table and attached to the **GRP** by means of a cable with 940k $\Omega$  total impedance. The equipment under test, was installed in a representative system as described in section 7 of IEC 61000-4-2, and its cables were placed on the **HCP** and isolated by an insulating support of 0.5mm thickness. A distance of 1-meter minimum was provided between the EUT and the walls of the laboratory and any other metallic structure.

##### FLOOR-STANDING EQUIPMENT

The equipment under test was installed in a representative system as described in section 7 of IEC 61000-4-2, and its cables were isolated from the Ground Reference Plane by an insulating support of 0.1-meter thickness. The GRP consisted of a sheet of aluminum that is at least 0.25mm thick, and 2.5 meters square connected to the protective grounding system and extended at least 0.5 meters from the EUT on all sides.



8.3.5. TEST RESULTS

Temperature	25°C	Humidity	48% RH
Pressure	1001mbar	Tested By	Moore Cheng
Test Mode	Mode 1	Required Passing Performance	Criterion B

Air Discharge												
Test Points	Test Levels						Results					
	± 2 kV	Performance Criterion		± 4 kV	Performance Criterion		± 8 kV	Performance Criterion		Pass	Fail	Observation
Front	<input type="checkbox"/>	<input type="checkbox"/> A	<input type="checkbox"/> B	<input type="checkbox"/>	<input type="checkbox"/> A	<input type="checkbox"/> B	<input type="checkbox"/>	<input type="checkbox"/> A	<input type="checkbox"/> B	<input type="checkbox"/>	<input type="checkbox"/>	Note 2
Back	<input type="checkbox"/>	<input type="checkbox"/> A	<input type="checkbox"/> B	<input type="checkbox"/>	<input type="checkbox"/> A	<input type="checkbox"/> B	<input type="checkbox"/>	<input type="checkbox"/> A	<input type="checkbox"/> B	<input type="checkbox"/>	<input type="checkbox"/>	Note 2
Left	<input checked="" type="checkbox"/>	<input checked="" type="checkbox"/> A	<input type="checkbox"/> B	<input checked="" type="checkbox"/>	<input checked="" type="checkbox"/> A	<input type="checkbox"/> B	<input checked="" type="checkbox"/>	<input checked="" type="checkbox"/> A	<input type="checkbox"/> B	<input checked="" type="checkbox"/>	<input type="checkbox"/>	Note 1
Right	<input checked="" type="checkbox"/>	<input checked="" type="checkbox"/> A	<input type="checkbox"/> B	<input checked="" type="checkbox"/>	<input checked="" type="checkbox"/> A	<input type="checkbox"/> B	<input checked="" type="checkbox"/>	<input checked="" type="checkbox"/> A	<input type="checkbox"/> B	<input checked="" type="checkbox"/>	<input type="checkbox"/>	Note 1
Top	<input checked="" type="checkbox"/>	<input checked="" type="checkbox"/> A	<input type="checkbox"/> B	<input checked="" type="checkbox"/>	<input checked="" type="checkbox"/> A	<input type="checkbox"/> B	<input checked="" type="checkbox"/>	<input checked="" type="checkbox"/> A	<input type="checkbox"/> B	<input checked="" type="checkbox"/>	<input type="checkbox"/>	Note 1
Bottom	<input type="checkbox"/>	<input type="checkbox"/> A	<input type="checkbox"/> B	<input type="checkbox"/>	<input type="checkbox"/> A	<input type="checkbox"/> B	<input type="checkbox"/>	<input type="checkbox"/> A	<input type="checkbox"/> B	<input type="checkbox"/>	<input type="checkbox"/>	Note 2

Contact Discharge												
Test Points	Test Levels						Results					
	± 2 kV	Performance Criterion		± 4 kV	Performance Criterion		± 8 kV	Performance Criterion		Pass	Fail	Observation
Front	<input checked="" type="checkbox"/>	<input checked="" type="checkbox"/> A	<input type="checkbox"/> B	<input checked="" type="checkbox"/>	<input checked="" type="checkbox"/> A	<input type="checkbox"/> B	<input type="checkbox"/>	<input type="checkbox"/> A	<input type="checkbox"/> B	<input checked="" type="checkbox"/>	<input type="checkbox"/>	Note 1
Back	<input checked="" type="checkbox"/>	<input checked="" type="checkbox"/> A	<input type="checkbox"/> B	<input checked="" type="checkbox"/>	<input checked="" type="checkbox"/> A	<input type="checkbox"/> B	<input type="checkbox"/>	<input type="checkbox"/> A	<input type="checkbox"/> B	<input checked="" type="checkbox"/>	<input type="checkbox"/>	Note 1
Left	<input type="checkbox"/>	<input type="checkbox"/> A	<input type="checkbox"/> B	<input type="checkbox"/>	<input type="checkbox"/> A	<input type="checkbox"/> B	<input type="checkbox"/>	<input type="checkbox"/> A	<input type="checkbox"/> B	<input type="checkbox"/>	<input type="checkbox"/>	Note 2
Right	<input type="checkbox"/>	<input type="checkbox"/> A	<input type="checkbox"/> B	<input type="checkbox"/>	<input type="checkbox"/> A	<input type="checkbox"/> B	<input type="checkbox"/>	<input type="checkbox"/> A	<input type="checkbox"/> B	<input type="checkbox"/>	<input type="checkbox"/>	Note 2
Top	<input checked="" type="checkbox"/>	<input checked="" type="checkbox"/> A	<input type="checkbox"/> B	<input checked="" type="checkbox"/>	<input checked="" type="checkbox"/> A	<input type="checkbox"/> B	<input type="checkbox"/>	<input type="checkbox"/> A	<input type="checkbox"/> B	<input checked="" type="checkbox"/>	<input type="checkbox"/>	Note 1
Bottom	<input type="checkbox"/>	<input type="checkbox"/> A	<input type="checkbox"/> B	<input type="checkbox"/>	<input type="checkbox"/> A	<input type="checkbox"/> B	<input type="checkbox"/>	<input type="checkbox"/> A	<input type="checkbox"/> B	<input type="checkbox"/>	<input type="checkbox"/>	Note 2

For the tested points to EUT, please refer to attached page. (Red arrow mark for Contact Discharge and Blue arrow mark for Air Discharge)

Discharge To Horizontal Coupling Plane								
Side of EUT	Test Levels			Results				
	± 2 kV	± 4 kV	± 8 kV	Pass	Fail	Performance Criterion		Observation
Front	<input checked="" type="checkbox"/>	<input checked="" type="checkbox"/>	<input type="checkbox"/>	<input checked="" type="checkbox"/>	<input type="checkbox"/>	<input checked="" type="checkbox"/> A	<input type="checkbox"/> B	Note 1
Back	<input checked="" type="checkbox"/>	<input checked="" type="checkbox"/>	<input type="checkbox"/>	<input checked="" type="checkbox"/>	<input type="checkbox"/>	<input checked="" type="checkbox"/> A	<input type="checkbox"/> B	Note 1
Left	<input checked="" type="checkbox"/>	<input checked="" type="checkbox"/>	<input type="checkbox"/>	<input checked="" type="checkbox"/>	<input type="checkbox"/>	<input checked="" type="checkbox"/> A	<input type="checkbox"/> B	Note 1
Right	<input checked="" type="checkbox"/>	<input checked="" type="checkbox"/>	<input type="checkbox"/>	<input checked="" type="checkbox"/>	<input type="checkbox"/>	<input checked="" type="checkbox"/> A	<input type="checkbox"/> B	Note 1

Discharge To Vertical Coupling Plane								
Side of EUT	Test Levels			Results				
	± 2 kV	± 4 kV	± 8 kV	Pass	Fail	Performance Criterion		Observation
Front	<input checked="" type="checkbox"/>	<input checked="" type="checkbox"/>	<input type="checkbox"/>	<input checked="" type="checkbox"/>	<input type="checkbox"/>	<input checked="" type="checkbox"/> A	<input type="checkbox"/> B	Note 1
Back	<input checked="" type="checkbox"/>	<input checked="" type="checkbox"/>	<input type="checkbox"/>	<input checked="" type="checkbox"/>	<input type="checkbox"/>	<input checked="" type="checkbox"/> A	<input type="checkbox"/> B	Note 1
Left	<input checked="" type="checkbox"/>	<input checked="" type="checkbox"/>	<input type="checkbox"/>	<input checked="" type="checkbox"/>	<input type="checkbox"/>	<input checked="" type="checkbox"/> A	<input type="checkbox"/> B	Note 1
Right	<input checked="" type="checkbox"/>	<input checked="" type="checkbox"/>	<input type="checkbox"/>	<input checked="" type="checkbox"/>	<input type="checkbox"/>	<input checked="" type="checkbox"/> A	<input type="checkbox"/> B	Note 1

Note:

1. There was no change compared with initial operation during the test.
2. Means that no discharge point had been occurred during that particular coupling method.



**The Photo for Discharge Points of EUT**

**Mode 1**

**Model : A-6188-D**









Model : A-6189D-D



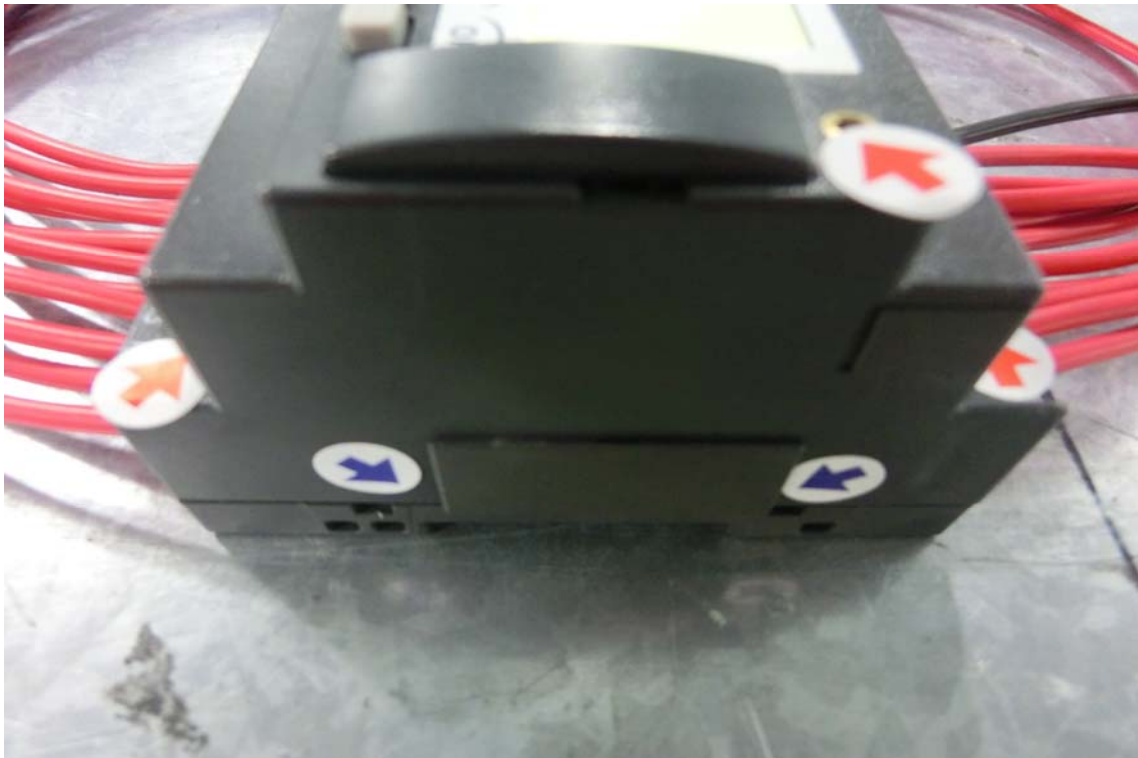







## 8.4. RADIATED, RADIO-FREQUENCY, ELECTROMAGNETIC FIELD (RS)

### 8.4.1. TEST SPECIFICATION

<b>Basic Standard:</b>	IEC 61000-4-3
<b>Frequency Range:</b>	80 MHz ~1000 MHz
<b>Field Strength:</b>	3 V/m
<b>Modulation:</b>	1kHz Sine Wave, 80%, AM Modulation
<b>Frequency Step:</b>	1 % of preceding frequency value
<b>Polarity of Antenna:</b>	Horizontal and Vertical
<b>Test Distance:</b>	3 m
<b>Antenna Height:</b>	1.5m



**8.4.2. TEST INSTRUMENT**

RS Chamber				
Name of Equipment	Manufacturer	Model	Serial Number	Calibration Due
S.G.	Agilent	E8257C	US42340383	09/24/2015
Power Meter	BOONTON	4232A-01-02	98501	02/18/2015
Power Sensor	BOONTON	51011-EMC	32862	02/18/2015
Power Sensor	BOONTON	51011-EMC	32864	02/18/2015
Power Amplifier	ar	150W1000M3	306730	N.C.R
Power Amplifier	ar	500W1000A	320994	N.C.R
Power Amplifier	ar	1000W1000D	0339180	N.C.R
Power Amplifier	ar	250T1G3M1	0320245	N.C.R
Power Amplifier	ar	300T2G8M1	0320255	N.C.R
Power Amplifier	ar	250T8G18M1	0320246	N.C.R
Dual Directional Coupler	ar	DC6180A	320285	N.C.R.
Dual Directional Coupler	ar	DC7144A	313674	N.C.R.
Dual Directional Coupler	ar	DC7280A	320524	N.C.R.
Dual Directional Coupler	ar	DC7450M1	320073	N.C.R.
RF Test System Controller	ar	SC1000M3	306666	N.C.R.
Bilog Antenna	ar	AT1080	306709	N.C.R
Horn Antenna	SCHWARZBEC K	BBHA 9120D	530	N.C.R.
EM PROBE	ar	FL7018	311430	08/15/2015
Test S/W	SW1006 (V1.13)			

**Note:**

1. The calibration interval of the above test instruments is 12 months and the calibrations are traceable to NML/ROC and NIST/USA.
2. N.C.R.= No Calibration required.



**8.4.3. TEST PROCEDURE** (please refer to measurement standard or CCS SOP PA-023)

The test procedure was in accordance with IEC 61000-4-3

- a) The testing was performed in a fully anechoic chamber. The transmit antenna was located at a distance of 3 meters from the EUT.
- b) The frequency range is swept from 80 MHz to 1000 MHz, with the signal 80% amplitude modulated with a 1kHz sine-wave. The rate of sweep did not exceed  $1.5 \times 10^{-3}$  decade/s, where the frequency range is swept incrementally, the step size was 1% of preceding frequency value.
- c) The dwell time at each frequency shall be not less than the time necessary for the EUT to be able to respond.
- e) The test was performed with the EUT exposed to both vertically and horizontally polarized fields on each of the four sides.

### 8.4.4. TEST SETUP

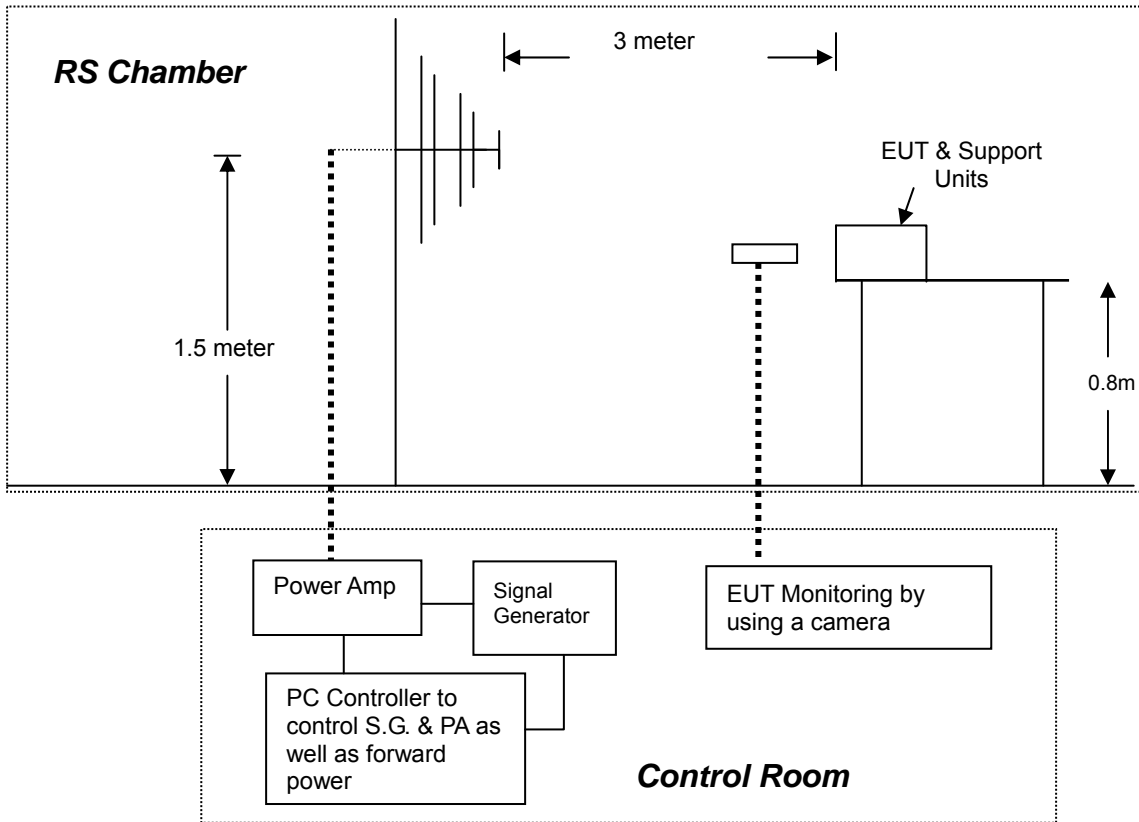

- For the actual test configuration, please refer to the related item – Photographs of the Test Configuration.

**Note:**

TABLETOP EQUIPMENT

The EUT installed in a representative system as described in section 7 of IEC 61000-4-3 was placed on a non-conductive table 0.8 meters in height. The system under test was connected to the power and signal wire according to relevant installation instructions.

FLOOR-STANDING EQUIPMENT

The EUT installed in a representative system as described in section 7 of IEC 61000-4-3 was placed on a non-conductive wood support 0.1 meters in height. The system under test was connected to the power and signal wire according to relevant installation instructions.



8.4.5. TEST RESULTS

Temperature	24°C	Humidity	45% RH
Pressure	1001mbar	Dwell Time	3 sec.
Tested By	Moore Cheng	Test Mode	Mode 1
Required Passing Performance	Criterion A		

Frequency (MHz)	Polarity	Azimuth	Field Strength (V/m)	Performance Criterion	Observation	Result
80 ~ 1000	V&H	0	3	<input checked="" type="checkbox"/> A <input type="checkbox"/> B	Note <input checked="" type="checkbox"/> 1 <input type="checkbox"/> 2	PASS
80 ~ 1000	V&H	90	3	<input checked="" type="checkbox"/> A <input type="checkbox"/> B	Note <input checked="" type="checkbox"/> 1 <input type="checkbox"/> 2	PASS
80 ~ 1000	V&H	180	3	<input checked="" type="checkbox"/> A <input type="checkbox"/> B	Note <input checked="" type="checkbox"/> 1 <input type="checkbox"/> 2	PASS
80 ~ 1000	V&H	270	3	<input checked="" type="checkbox"/> A <input type="checkbox"/> B	Note <input checked="" type="checkbox"/> 1 <input type="checkbox"/> 2	PASS

Note: 1. There was no change compared with the initial operation during the test.



### 8.5. ELECTRICAL FAST TRANSIENT (EFT)

#### 8.5.1. TEST SPECIFICATION

<b>Basic Standard:</b>	IEC 61000-4-4
<b>Test Voltage:</b>	AC Power Port: 1kV DC Power Port: 0.5kV Signal Ports and Telecommunication Ports: 0.5kV
<b>Polarity:</b>	Positive & Negative
<b>Impulse Frequency:</b>	5 kHz
<b>Impulse Wave-shape:</b>	5/50 ns
<b>Burst Duration:</b>	15 ms
<b>Burst Period:</b>	300 ms
<b>Test Duration:</b>	Not less than 1 min.

#### 8.5.2. TEST INSTRUMENT

Immunity Shield Room				
Name of Equipment	Manufacturer	Model	Serial Number	Calibration Due
EMC Immunity Tester	EMC Partner	TRA2000IN6	1144	01/02/2015
CDN	EMC Partner	CDCN-UTP8	046	01/08/2015
Test S/W	Genecs (3.03)			

**Note:**

1. The calibration interval of the above test instruments is 12 months and the calibrations are traceable to NML/ROC and NIST/USA.
2. N.C.R.= No Calibration required

#### 8.5.3. TEST PROCEDURE (please refer to measurement standard or CCS SOP PA-024)

- a) Both positive and negative polarity discharges were applied.
- b) The length of the "hot wire" from the coaxial output of the EFT generator to the terminals on the EUT should not exceed 0.5 meter.
- c) The duration time of each test sequential was 1 minute.
- d) The transient/burst waveform was in accordance with IEC 61000-4-4, 5/50ns.



### 8.5.4. TEST SETUP

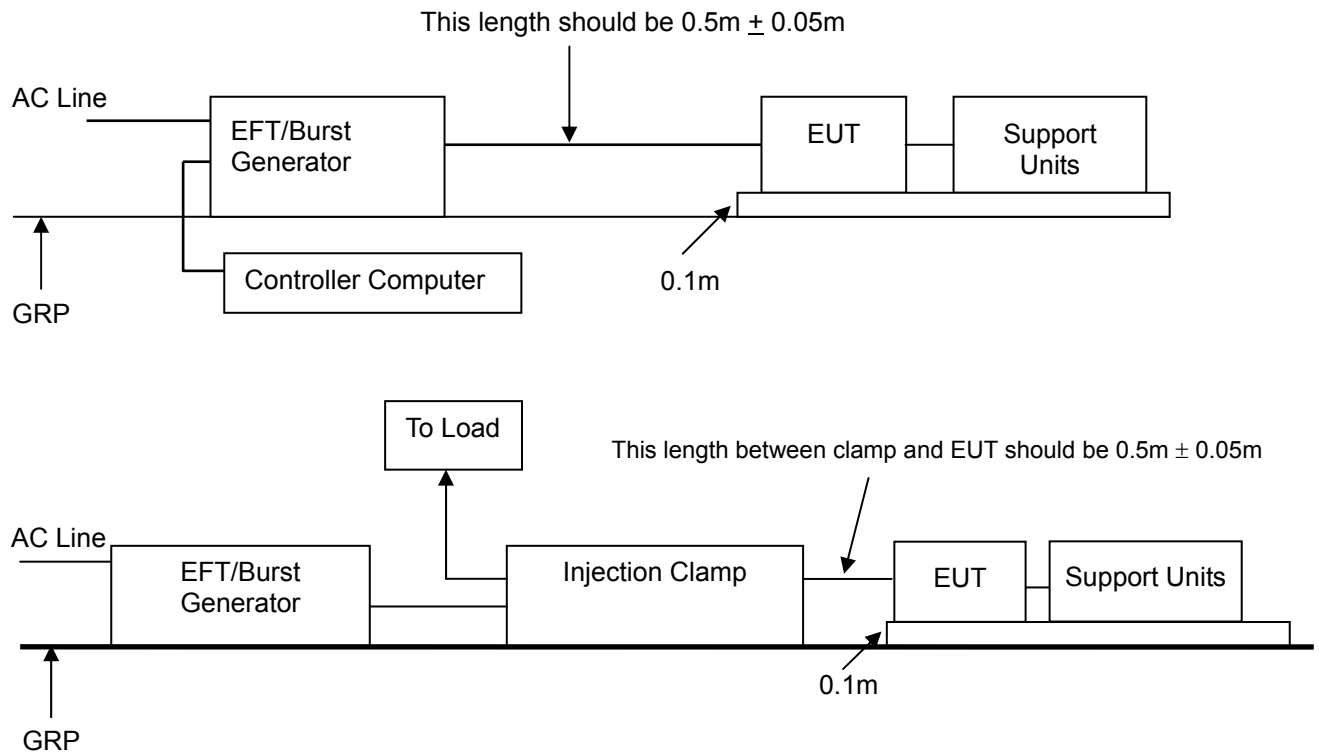

- For the actual test configuration, please refer to the related item – Photographs of the Test Configuration.

**Note:**

TABLETOP EQUIPMENT

The configuration consisted of a wooden table (0.1m high) standing on the Ground Reference Plane. The GRP consisted of a sheet of aluminum (at least 0.25mm thick and 2.5m square) connected to the protective grounding system. A minimum distance of 0.5m was provided between the EUT and the walls of the laboratory or any other metallic structure.

FLOOR-STANDING EQUIPMENT

The EUT installed in a representative system as described in section 7 of IEC 61000-4-4 and its cables, were isolated from the Ground Reference Plane by an insulating support that is 0.1-meter thick. The GRP consisted of a sheet of aluminum (at least 0.25mm thick and 2.5m square) connected to the protective grounding system.



8.5.5. TEST RESULTS

Temperature	22.4°C	Humidity	53% RH
Pressure	1001mbar	Tested By	Jason Yang
Test Mode	Mode 1	Required Passing Performance	Criterion B

Test Point	Polarity	Test Level (kV)	Performance Criterion	Observation	Result
Positive	+/-	0.5	<input checked="" type="checkbox"/> A <input type="checkbox"/> B	Note <input checked="" type="checkbox"/> 1 <input type="checkbox"/> 2	PASS
Negative	+/-	0.5	<input checked="" type="checkbox"/> A <input type="checkbox"/> B	Note <input checked="" type="checkbox"/> 1 <input type="checkbox"/> 2	PASS
Positive + Negative	+/-	0.5	<input checked="" type="checkbox"/> A <input type="checkbox"/> B	Note <input checked="" type="checkbox"/> 1 <input type="checkbox"/> 2	PASS

**Note:** 1. There was no change compared with initial operation during the test.





### 8.6. SURGE IMMUNITY TEST

#### 8.6.1. TEST SPECIFICATION

<b>Basic Standard:</b>	IEC 61000-4-5
<b>Wave-Shape:</b>	Combination Wave for power port 1.2/50µs Open Circuit Voltage 8/20µs Short Circuit Current
<b>Test Voltage:</b>	Combination Wave for Signal and Telecommunication port 10/700µs Open Circuit Voltage 5/320µs Short Circuit Current  AC Power Port ~ line to line: 1kV, line to earth (ground): 2kV DC Power Port ~ line to earth: 0.5kV Performance Criterion B Signal and Telecommunication Ports ~ line to ground: 1kV Performance Criterion C
<b>Surge Input/Output:</b>	AC Power Line: L - N
<b>Generator Source Impedance:</b>	2 ohm between networks 12 ohm between network and ground
<b>Polarity:</b>	Positive/Negative
<b>Phase Angle:</b>	0° / 90° / 180° / 270°
<b>Pulse Repetition Rate:</b>	1 time / min. (maximum)
<b>Number of Tests:</b>	5 positive and 5 negative at selected points

#### 8.6.2. TEST INSTRUMENT

Immunity Shield Room				
Name of Equipment	Manufacturer	Model	Serial Number	Calibration Due
EMC Immunity Tester	EMC Partner	TRA2000IN6	1144	01/02/2015
CDN	EMC Partner	CDCN-UTP8	046	01/08/2015
Test S/W	Genecs (3.03)			

**Note:**

- The calibration interval of the above test instruments is 12 months and the calibrations are traceable to NML/ROC and NIST/USA.
- N.C.R.= No Calibration required



**8.6.3. TEST PROCEDURE** (please refer to measurement standard or CCS SOP PA-025)

a) For EUT power supply:

The surge is applied to the EUT power supply terminals via the capacitive coupling network. Decoupling networks are required in order to avoid possible adverse effects on equipment not under test that may be powered by the same lines, and to provide sufficient decoupling impedance to the surge wave. The power cord between the EUT and the coupling/decoupling networks was shorter than 2 meters in length.

b) For test applied to unshielded un-symmetrically operated interconnection lines of EUT:

The surge was applied to the lines via the capacitive coupling. The coupling / decoupling networks didn't influence the specified functional conditions of the EUT. The interconnection line between the EUT and the coupling/decoupling networks was shorter than 2 meters in length.

c) For test applied to unshielded symmetrically operated interconnection / telecommunication lines of EUT:

The surge was applied to the lines via gas arrestors coupling. Test levels below the ignition point of the coupling arrestor were not specified. The interconnection line between the EUT and the coupling/decoupling networks was shorter than 2 meters in length.



8.6.4. TEST SETUP

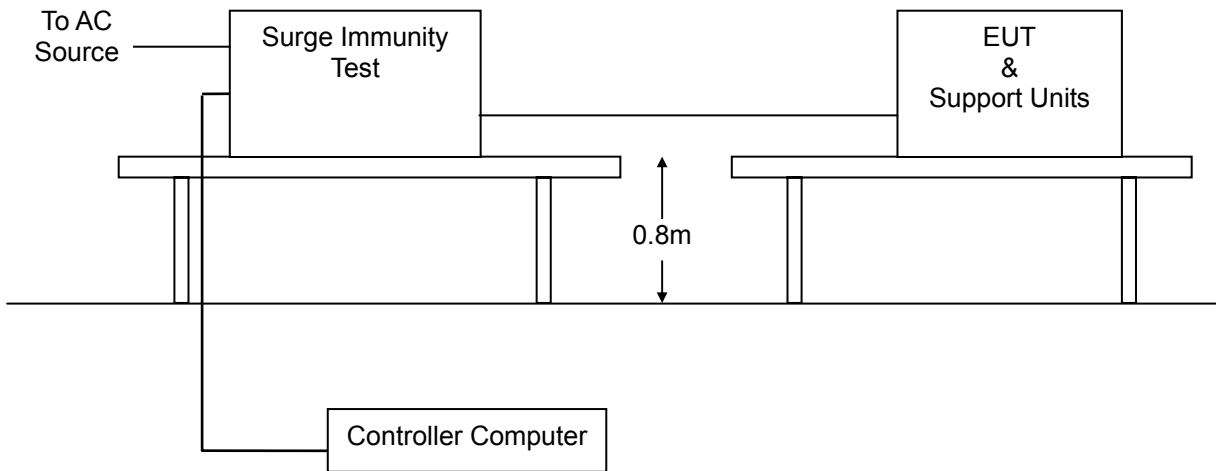

- For the actual test configuration, please refer to the related item – Photographs of the Test Configuration.

8.6.5. TEST RESULTS

Temperature	25°C	Humidity	48% RH
Pressure	998mbar	Tested By	Jason Yang
Test Mode	Mode 1	Required Passing Performance	Criterion B

Test Point	Polarity	Test Level (kV)	Performance Criterion	Observation	Result
Positive - Negative	+/-	0.5	<input checked="" type="checkbox"/> A <input type="checkbox"/> B	Note <input checked="" type="checkbox"/> 1 <input type="checkbox"/> 2	PASS

**Note:** 1. There was no change compared with initial operation during the test.



## 8.7. CONDUCTED RADIO FREQUENCY DISTURBANCES (CS)

### 8.7.1. TEST SPECIFICATION

**Basic Standard:** IEC 61000-4-6

**Frequency Range:** 0.15 MHz ~ 80 MHz

**Field Strength:** 3 Vrms

**Modulation:** 1kHz Sine Wave, 80%, AM Modulation

**Frequency Step:** 1 % of preceding frequency value

**Coupled cable:** Power Mains, Unshielded; LAN, Line, Unshielded

**Coupling device:**

- CDN-M2 (2 wires)
- CDN-M3 (3 wires)
- CDN-T2 for Line
- CDN-T8 for LAN



8.7.2. TEST INSTRUMENT

CS Room				
Name of Equipment	Manufacturer	Model	Serial Number	Calibration Due
S.G.	R&S	SMY02	100094	09/30/2015
Power Meter	BOONTON	4242	13760	01/06/2015
Power Sensor	BOONTON	51013-4E	35522	01/06/2015
Power Sensor	BOONTON	51013-4E	35523	01/06/2015
Power Amplifier	ar	500A100A	300299	N.C.R
Dual Directional Coupler	ar	DC2600A	306621	N.C.R.
Attenuator	EPX	ECA500-6-1-NF-NM	0809180	N.C.R.
CDN	FCC	FCC-801-M2-16A	121695	12/10/2014
CDN	FCC	FCC-801-M3-16A	03027	10/14/2015
CDN	FCC	FCC-801-T2	03016	10/14/2015
CDN	FCC	FCC-801-T4	03017	10/14/2015
CDN	FCC	FCC-801-T8-RJ45	04024	10/14/2015
EM Injection Clamp	FCC	F-203I-23mm	421	12/24/2014
S.G.	R&S	SMY02	100094	09/30/2015
Power Meter	BOONTON	4242	13760	01/06/2015
Power Sensor	BOONTON	51013-4E	34241	11/10/2014
Power Sensor	BOONTON	51013-4E	35087	11/10/2014
Test S/W	SW1006 (V1.22)			

**Note:**

1. The calibration interval of the above test instruments is 12 months and the calibrations are traceable to NML/ROC and NIST/USA.
2. N.C.R.= No Calibration required

**8.7.3. TEST PROCEDURE** (please refer to measurement standard or CCS SOP PA-026)

The EUT shall be tested within its intended operating and climatic conditions.

The test shall be performed with the test generator connected to each of the coupling and decoupling devices in turn, while the other non-excited RF input ports of the coupling devices are terminated by a 50-ohm load resistor.

The frequency range was swept from 150 kHz to 80 MHz, using the signal level established during the setting process and with a disturbance signal of 80 % amplitude. The signal was modulated with a 1 kHz sine wave, pausing to adjust the RF signal level or the switch coupling devices as necessary. The sweep rate was  $1.5 \times 10^{-3}$  decades/s. Where the frequency range is swept incrementally, the step size was 1 % of preceding frequency value from 150 kHz to 80 MHz.

The dwell time at each frequency was less than the time necessary for the EUT to be exercised, and able to respond. Sensitive frequencies such as clock frequency(ies) and harmonics or frequencies of dominant interest, was analyzed separately.

Attempts were made to fully exercise the EUT during testing, and to fully interrogate all exercise modes selected for susceptibility.

**8.7.4. TEST SETUP**

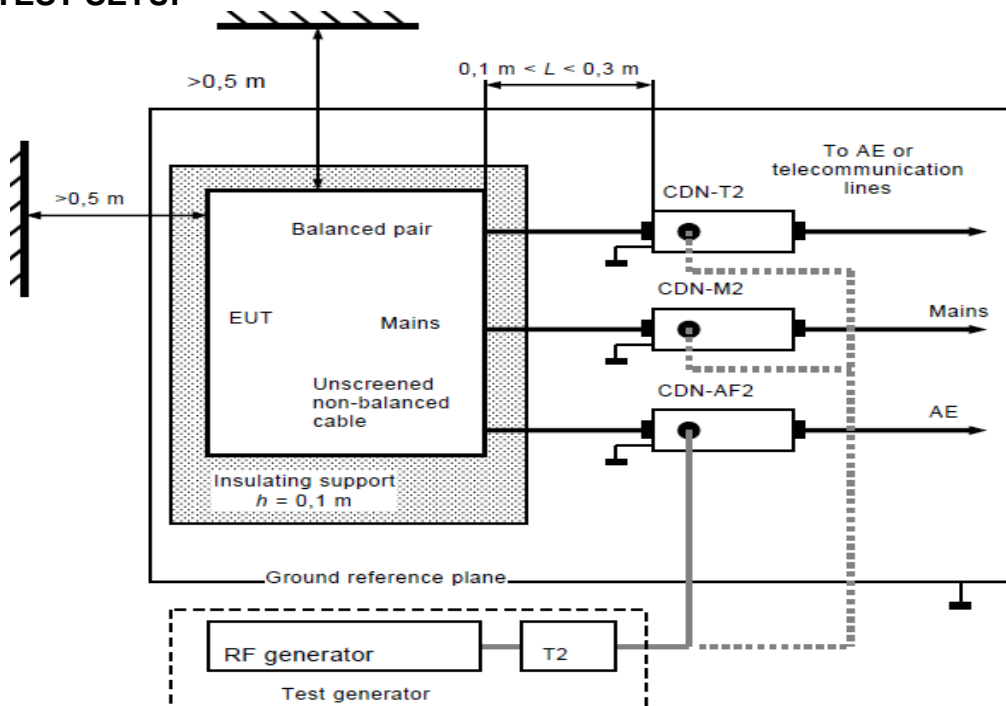

**Note:**

1. The EUT is setup 0.1m above Ground Reference Plane
2. The CDNs and / or EM clamp used for real test depend on ports and cables configuration of EUT.

- For the actual test configuration, please refer to the related item – Photographs of the Test Configuration.

**Note:**

TABLETOP AND FLOOR-STANDING EQUIPMENT

The equipment to be tested is placed on an insulating support of 0.1 meters height above a ground reference plane. All relevant cables shall be provided with the appropriate coupling and decoupling devices at a distance between 0.1 meters and 0.3 meters from the projected geometry of the EUT on the ground reference plane.



8.7.5. TEST RESULTS

Temperature	25°C	Humidity	50% RH
Pressure	999mbar	Tested By	Bland Cheng
Test Mode	Mode 1	Required Passing Performance	Criterion A

Frequency Band (MHz)	Field Strength (Vrms)	Cable	Injection Method	Performance Criterion	Observation	Result
0.15 ~ 80	3	DC Power Line	CDN-M2	<input checked="" type="checkbox"/> A <input type="checkbox"/> B	Note <input checked="" type="checkbox"/> 1 <input type="checkbox"/> 2	PASS

**Note:** 1. There was no change compared with initial operation during the test.



## 8.8. POWER FREQUENCY MAGNETIC FIELD

### 8.8.1. TEST SPECIFICATION

<b>Basic Standard:</b>	IEC 61000-4-8
<b>Frequency Range:</b>	50Hz
<b>Field Strength:</b>	1 A/m
<b>Observation Time:</b>	1 minute
<b>Inductance Coil:</b>	Rectangular type, 1mx1m

### 8.8.2. TEST INSTRUMENT

Immunity Shield Room				
Name of Equipment	Manufacturer	Model	Serial Number	Calibration Due
Triax Elf Magnetic Field Meter	F.W.BELL	4190	0845014	02/20/2015
Clamp Meter	DHA	CM-312A	W3010087	07/01/2015
Magnetic Field Tester	HAEFELY TRENCH	MAG 100.1	081 436-02	N.C.R.
Frequency Converter	EXTECH	CFC-105	810390	N.C.R.

**Note:**

1. The calibration interval of the above test instruments is 12 months and the calibrations are traceable to NML/ROC and NIST/USA.
2. N.C.R.= No Calibration required

### 8.8.3. TEST PROCEDURE (please refer to measurement standard or CCS SOP PA-027)

- a) The equipment is configured and connected to satisfy its functional requirements. It shall be placed on the GRP with the interposition of a 0.1m-thick insulating support.
- b) The equipment cabinets shall be connected to the safety earth directly on the GRP via the earth terminal of the EUT.
- c) The power supply, input and output circuits shall be connected to the sources of power supply, control and signal.
- d) The cables supplied or recommended by the equipment manufacturer shall be used. 1 meter of all cables used shall be exposed to the magnetic field.





#### 8.8.4. TEST SETUP

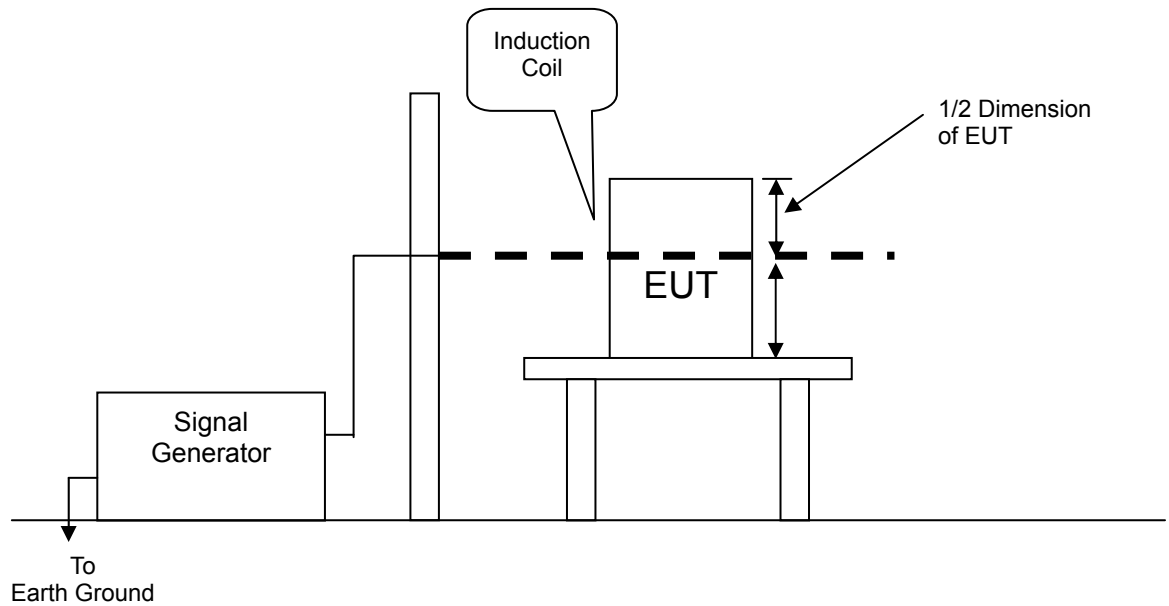

- For the actual test configuration, please refer to the related item – Photographs of the Test Configuration.

**Note:**

TABLETOP EQUIPMENT

The equipment shall be subjected to the test magnetic field by using the induction coil of standard dimension (1 m x 1 m). The induction coil shall then be rotated by 90 degrees in order to expose the EUT to the test field with different orientations.

FLOOR-STANDING EQUIPMENT

The equipment shall be subjected to the test magnetic field by using induction coils of suitable dimensions. The test shall be repeated by moving and shifting the induction coils, in order to test the whole volume of the EUT for each orthogonal direction. The test shall be repeated with the coil shifted to different positions along the side of the EUT, in steps corresponding to 50 % of the shortest side of the coil. The induction coil shall then be rotated by 90 degrees in order to expose the EUT to the test field with different orientations.



8.8.5. TEST RESULTS

Temperature	24°C	Humidity	45% RH
Pressure	1001mbar	Tested By	Moore Cheng
Test Mode	Mode 1	Required Passing Performance	Criterion A

DIRECTION	Field Strength (A/m)	Performance Criterion	OBSERVATION	RESULTS
X	1	<input checked="" type="checkbox"/> A <input type="checkbox"/> B	Note <input checked="" type="checkbox"/> 1 <input type="checkbox"/> 2	PASS
Y	1	<input checked="" type="checkbox"/> A <input type="checkbox"/> B	Note <input checked="" type="checkbox"/> 1 <input type="checkbox"/> 2	PASS
Z	1	<input checked="" type="checkbox"/> A <input type="checkbox"/> B	Note <input checked="" type="checkbox"/> 1 <input type="checkbox"/> 2	PASS

**Note:** 1. There was no change compared with the initial operation during the test.



## 8.9. VOLTAGE DIP & VOLTAGE INTERRUPTIONS

### 8.9.1. TEST SPECIFICATION

<b>Basic Standard:</b>	IEC 61000-4-11
<b>Test duration time:</b>	Minimum three test events in sequence
<b>Interval between event:</b>	Minimum 10 seconds
<b>Phase Angle:</b>	0° / 45° / 90° / 135° / 180° / 225° / 270° / 315°
<b>Test cycle:</b>	3 times

### 8.9.2. TEST INSTRUMENT

Immunity Shield Room				
Name of Equipment	Manufacturer	Model	Serial Number	Calibration Due
N/A				

### 8.9.3. TEST PROCEDURE (please refer to measurement standard or CCS SOP PA-028)

- a) The EUT and support units were located on a wooden table, 0.8 m away from ground floor.
- b) Setting the parameter of tests and then perform the test software of test simulator.
- c) Conditions changes to occur at 0 degree crossover point of the voltage waveform.
- d) Recording the test result in test record form.



#### 8.9.4. TEST SETUP

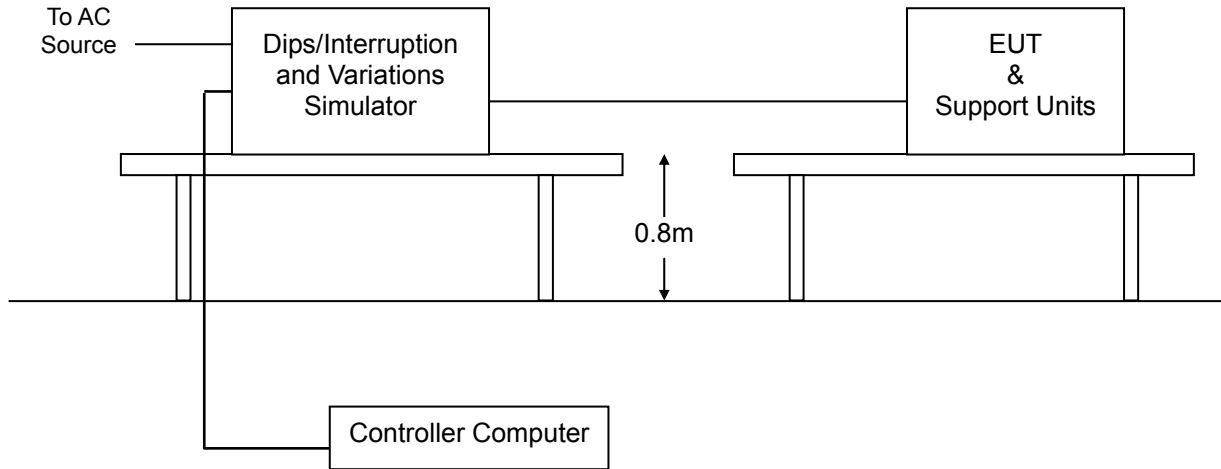

- For the actual test configuration, please refer to the related item – Photographs of the Test Configuration.

#### 8.9.5. TEST RESULTS

***Not applicable, because EUT not connect to AC Main Source direct.***



## 9 PHOTOGRAPHS OF THE TEST CONFIGURATION

### RADIATED EMISSION TEST

Below 1GHz

Mode 1





**ESD TEST**

**Mode 1**



**RADIATED ELECTROMAGNETIC FIELD TEST**

**Mode 1**

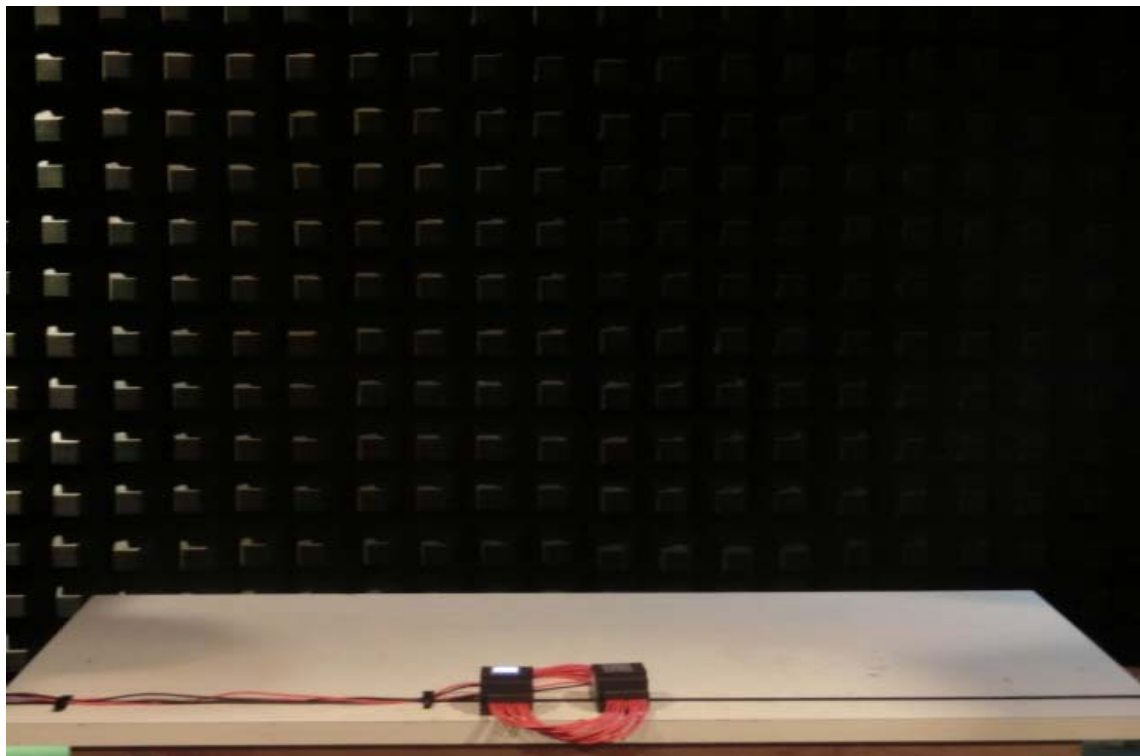



**FAST TRANSIENTS/BURST TEST**

**Mode 1**



**SURGE IMMUNITY TEST**

**Mode 1**

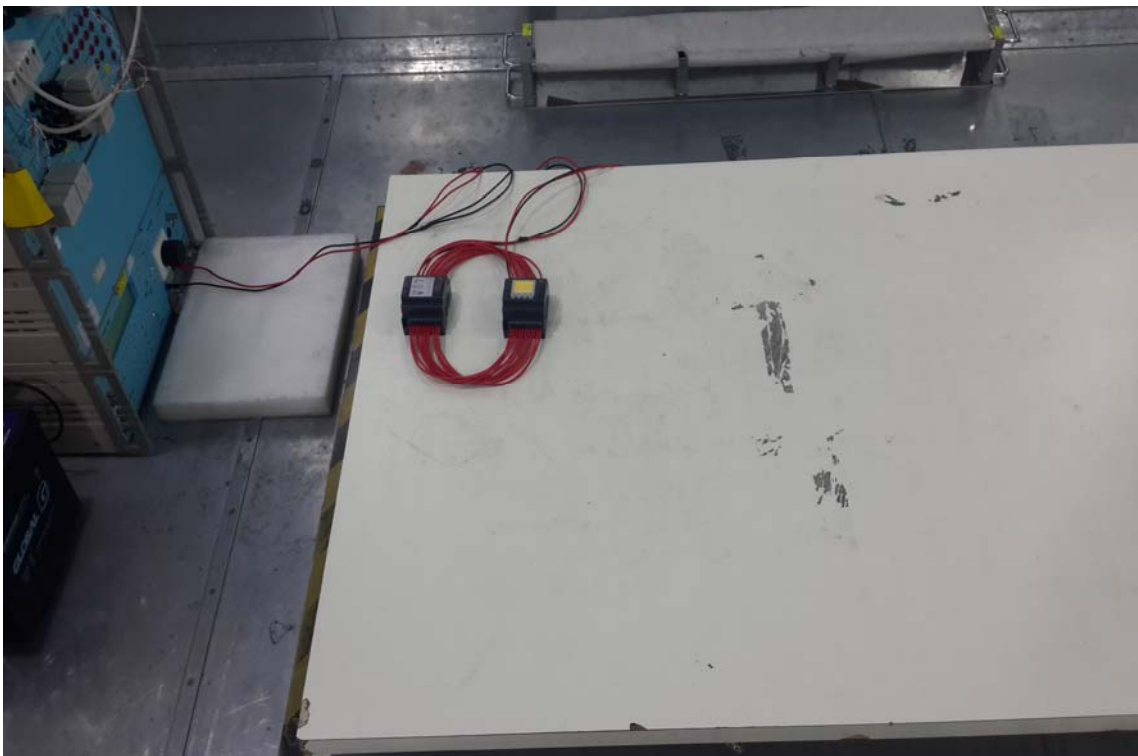



**CONDUCTED DISTURBANCE, INDUCED BY RADIO-FREQUENCY  
FIELDS TEST (Power)  
Mode 1**



**POWER FREQUENCY MAGNETIC FIELD IMMUNITY TEST  
Mode 1**

